

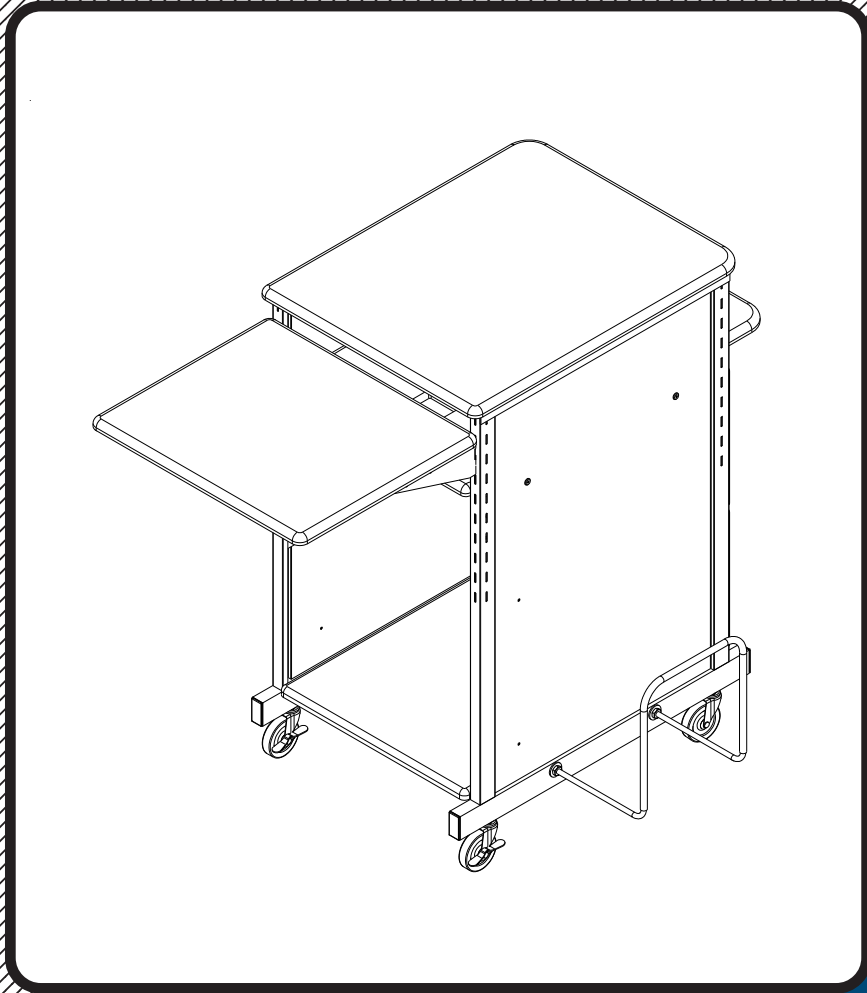

#27517 Xtra-Wide Presentation Cart











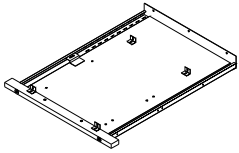
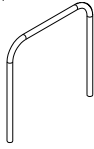
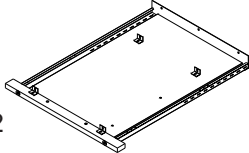

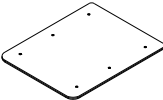
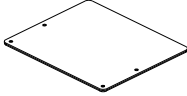

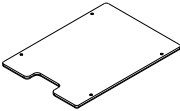
AV Cart W/Adjustable Height Shelf

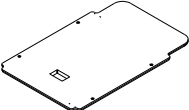

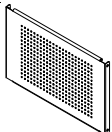
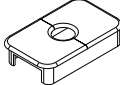
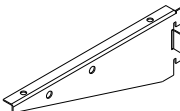
Assembly Instructions

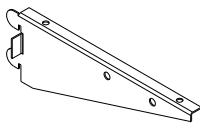
#27517 Xtra Wide Presentation Cart

AV Cart w/Adjustable Height Shelf

Part	Drawing	Description	Qty	Part	Drawing	Description	Qty
P1		Leg Assembly Left	1 EA	P-10		CPU Sleeve	1 EA
P2		Leg Assembly Right	1 EA	P-11		CPU Rod	2 EA
P3		Top Platform	1 EA	Hardware List			
P4		Laptop Shelf	1 EA	A		M6X12mm Socket Screw	26 EA
P5		Lower Shelf	1 EA	B		4" Locking Caster	2 EA
P6		LCD Platform	1 EA	C		4" Caster	2 EA
P7		Stability Panel	2 EA	D		Plastic Grommet	1 EA
P-8		Right Shelf Bracket	1 EA	E		Hex Nut	4 EA
P-9		Left Shelf Bracket	1 EA	F		Flat Washer	4 EA
				G		Black Plastic Spacer	2 EA
				H		Allen Wrench	1 EA
				J		Caster Wrench	1 EA

We recommend that you assemble this unit on a table.

Should you require assistance during assembly, please call our Customer Service Department Monday - Friday 8 a.m. - 5 p.m. Central Standard Time 1-800-749-2258

Do not use unless all screws are tight. At least every six months, check all screws to be sure they are tight. If parts are missing, broken, damaged, or worn, stop use of the product until repairs are made by your dealer using factory authorized parts.

#27517 Xtra-Wide Presentation Cart Assembly Diagram



READ THROUGH INSTRUCTIONS FROM BEGINNING TO END BEFORE STARTING TO ASSEMBLE UNIT.

Illustration # 1

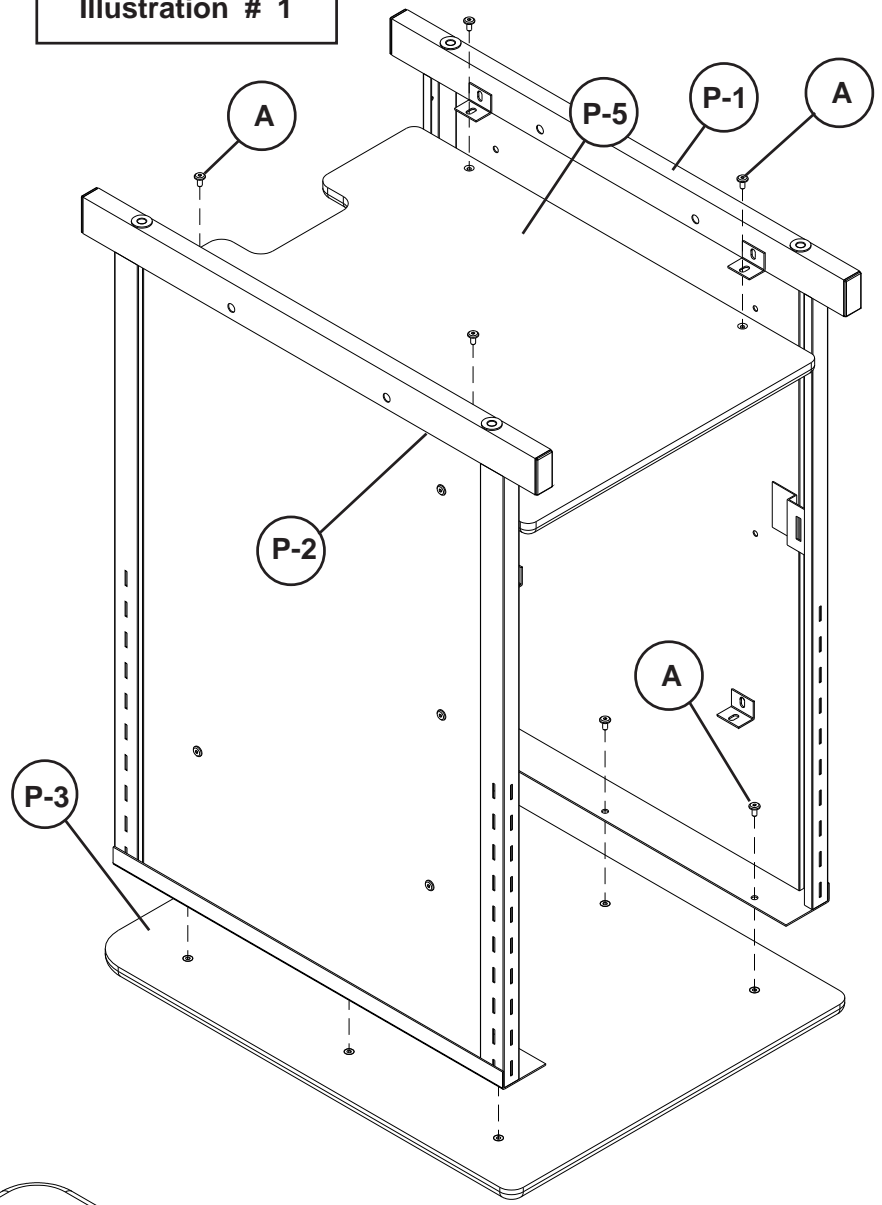

- 1.) Identify and Separate all the Parts and Hardware.
- 2.) Attach Top Platform (P-3) and Lower Shelf (P-5) to the Left & Right Leg Assemblies (P1 & P2) using 10 screws (A) as shown in illustration # 1.
(Finger tighten only)

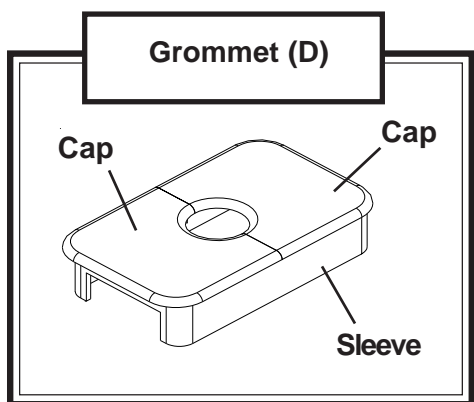

**Grommet(D) installation
Illustration # 2**

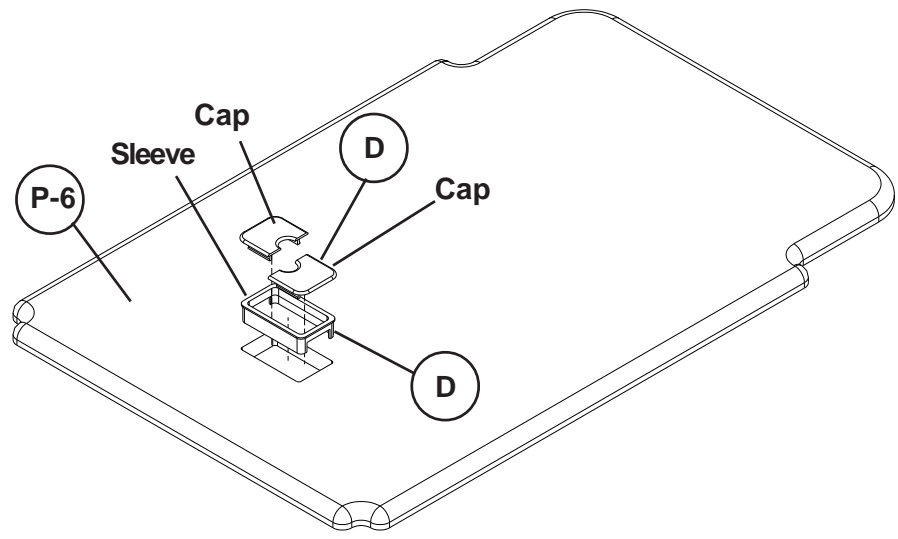

- 3.) To install Grommet (D) in LCD Platform (P-6), separate parts and press Grommet Sleeve in rectangular opening as shown in illustration # 2.
- 4.) Snap 2 plastic Caps over top of Sleeve as shown in illustration 2.

Illustration # 3

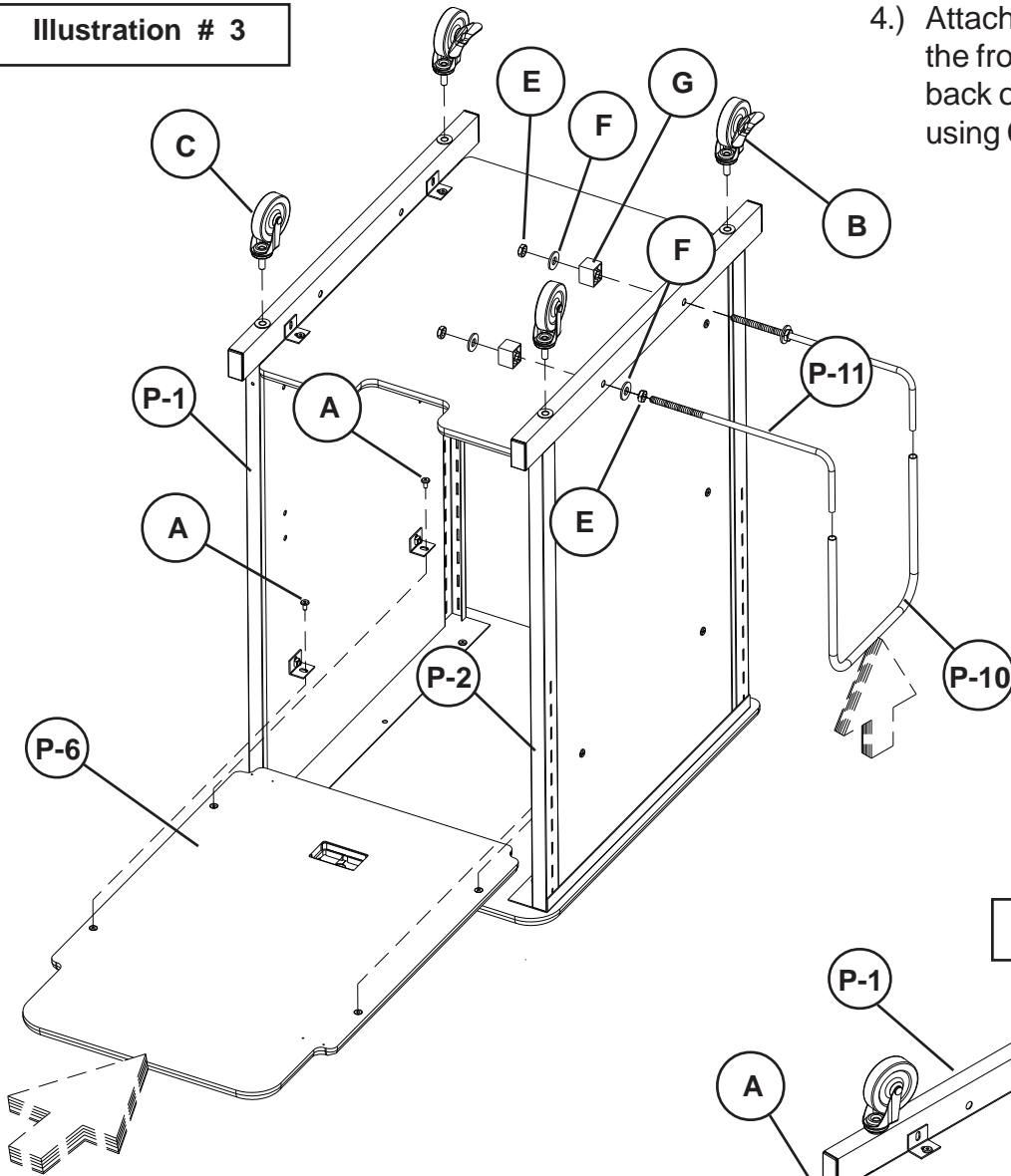

4.) Attach 2 Locking Casters (B) to the front, and 2 Casters (C) to the back of the unit. Tighten all Casters using Caster Wrench (J).

5.) Place 1 Hex Nut (E) and 1 Flat Washer (F) on each CPU Rod (P-11). Insert 2 CPU Rods (P-11) through the Left Leg (P-1) or the Right Leg (P-2) as shown in illustration # 3.

6.) Place 1 Black Plastic Spacer (G) over each CPU Rod (P-11) and secure each Rod with 1 Flat Washer (F) and 1 Hex Nut (E). Slide CPU Sleeve (P-10) over ends of CPU Rods as shown in illustration # 3.

Illustration # 4

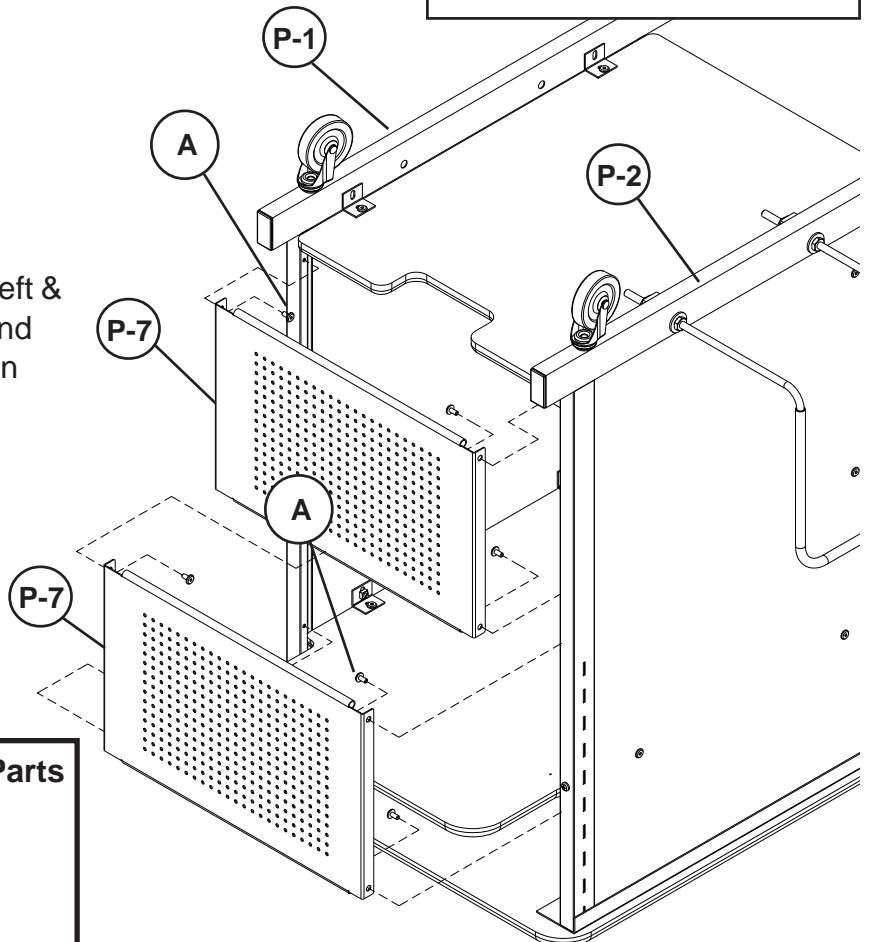

7.) Slide LCD Platform (P-6) Between Left & Right Leg Assemblies (P-1 & P-2) and attach using 4 Screws (A) as shown in illustration # 3.

8.) Attach 2 Stability Panels (P-7) to the Left & Right Leg Assemblies (P-1 & P-2) using 8 Screws (A) as shown in illustration # 4.
(Finger tighten only)

Missing Parts or UPS Damaged Parts

For Your Convenience you can
EMAIL us at

furniture@baltinc.com

24HOURS 7 DAYS A WEEK

Illustration # 5

9.) Attach Right Shelf Bracket (P-8) and Left Shelf Bracket (P-9) to Laptop Shelf (P-4) using 4 screws (A) as shown in illustration # 5. **(Finger tighten only)**

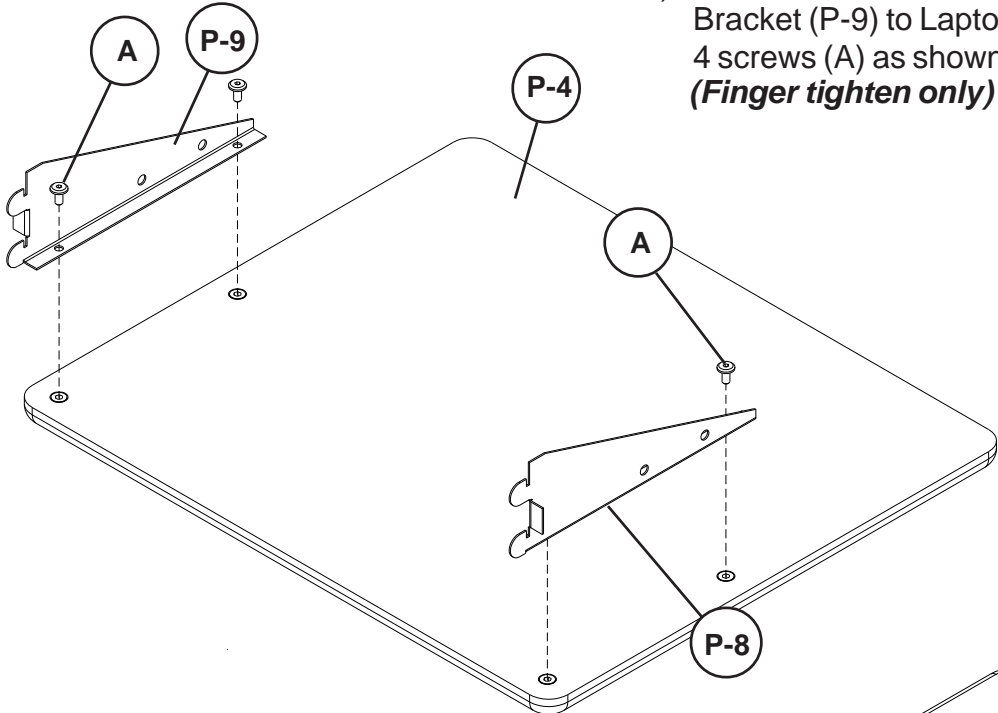
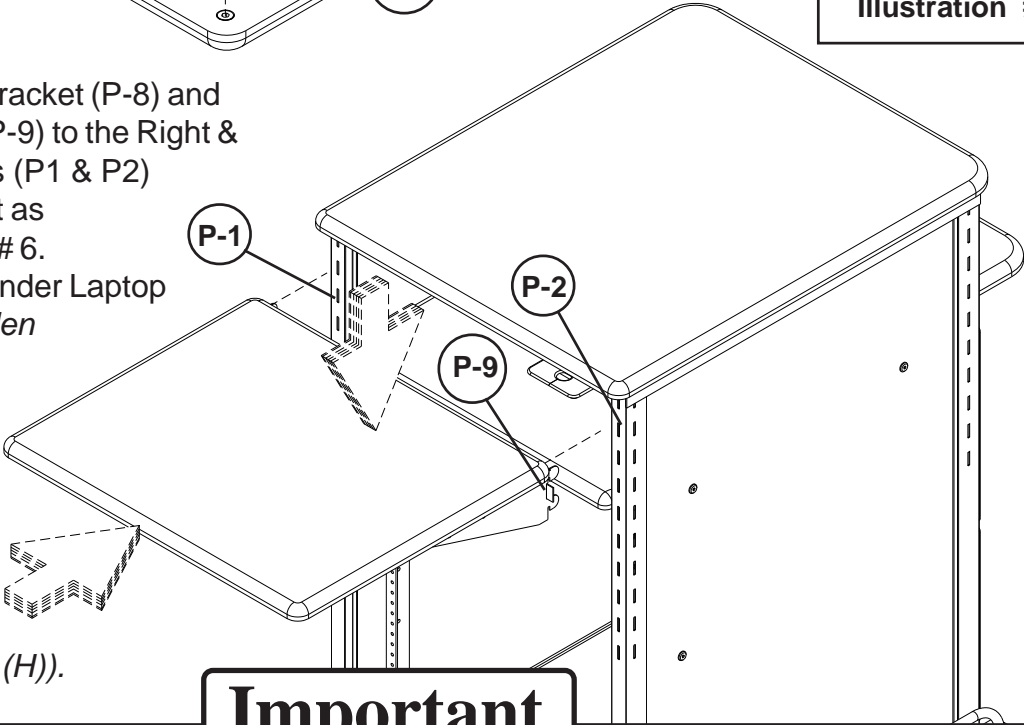

Illustration # 6

10.) Attach Right Shelf Bracket (P-8) and Left Shelf Bracket (P-9) to the Right & Left Leg Assemblies (P1 & P2) at the desired height as shown in illustration # 6. **(Tighten 4 screws under Laptop Shelf (P-4) using Allen Wrench (H)).**



(Tighten all the screws at this time using Allen Wrench (H)).

Important

The Balt product you have purchased is guaranteed against material and workmanship defects. This guarantee extends 1 year from date of purchase. Should this product fail to function satisfactorily under normal use due to defect or imperfection, the defective part or product will be replaced. Damage caused by common carriers during shipment is not included in this guarantee.

This guarantee sets forth all applicable guarantees and remedies. No other warranty, expressed or implied shall apply. Failure to follow instructions found in Important Information Section of Owner Sheet shall void the guarantee. Consequential or incidental damages and or costs are not refundable.