

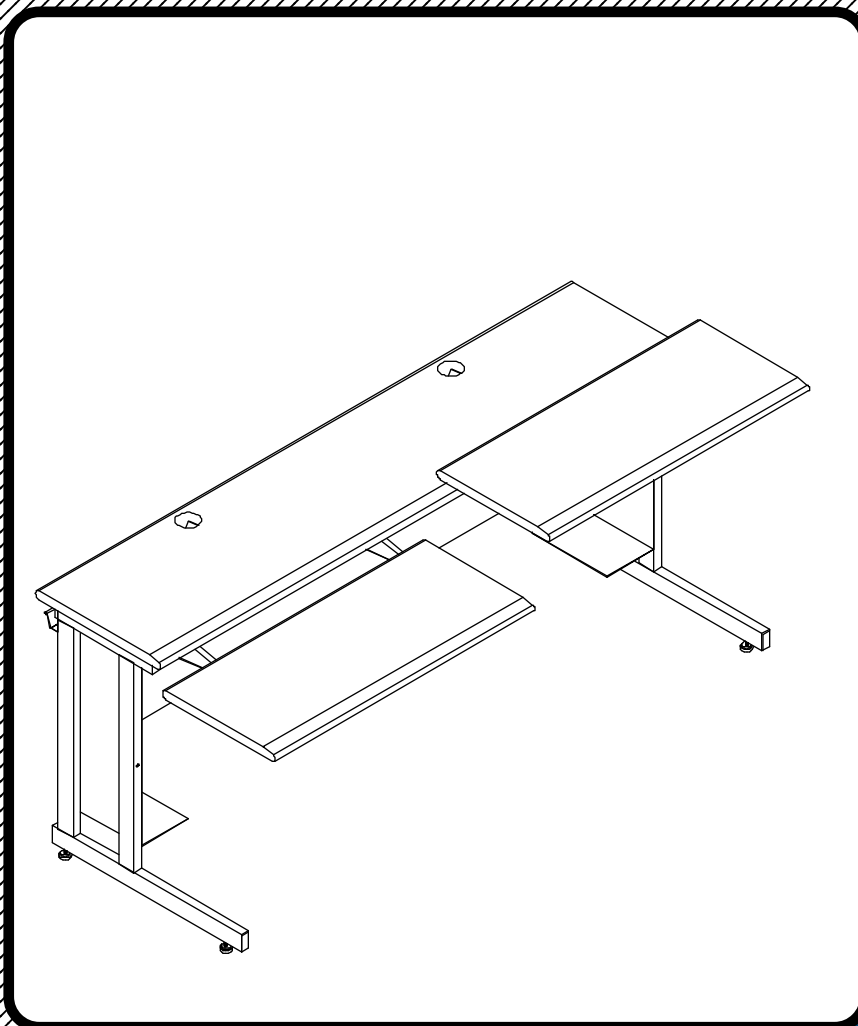

SMART-ONE 72





Dual Student Standup-Sit down Workstation

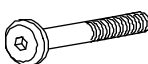

Assembly Instructions

Smart-One72

Dual Student Stand-Up/Sit down Workstation

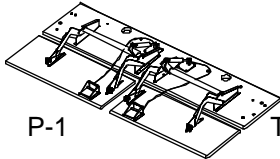
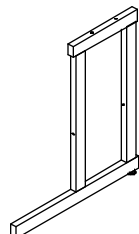
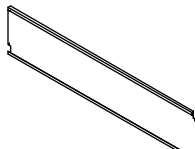
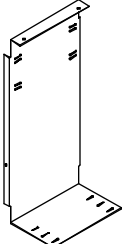
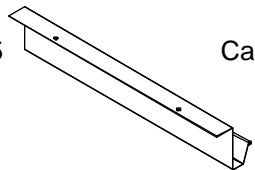
Part	Drawing	Description	Qty	Part	Drawing	Description	Qty
	Hardware List						
		Short Flat Head Screw	8 EA	A			
		Long Flat Head Screw	4 EA	A1			
		1" Sheet Metal Screw	8 EA	B			
		Flat Washer	4 EA	C			
		Allen Wrench	1 EA	F			
	Tools required: 1 Phillips Screwdriver						
P-1		Top Platforms w/Arms	1 EA				
P-2		Leg Assembly	2 EA				
P-3		Metal Stability Panel	1 EA				
P-4		Formed CPU Holder	2 EA				
P-5		Cable Tray	2 EA				



Missing Parts or UPS Damaged Parts

For Your Convenience you can
EMAIL us at

furniture@baltinc.com

24HOURS 7 DAYS A WEEK

***Should you require assistance during assembly,
please call our Customer Service Department***

Monday - Friday 8 a.m. - 5 p.m.

Central Standard Time 1-800-749-2258

Smart-One72 Assembly Diagram



To Assemble:

1. Identify and Separate all the Parts and Hardware.
2. Attach the 2 each Leg Assemblies (P-2) to the Top Platform w/Arms (P-1) using 4 each Long Flat Head Screws (A1) as shown in illustration # 1.
(Finger tighten only.)
3. Attach 2 each Cable Trays (P-5) to the Top Platform w/Arms (P-1) using 4 each short screws (A) as shown in illustration # 1.

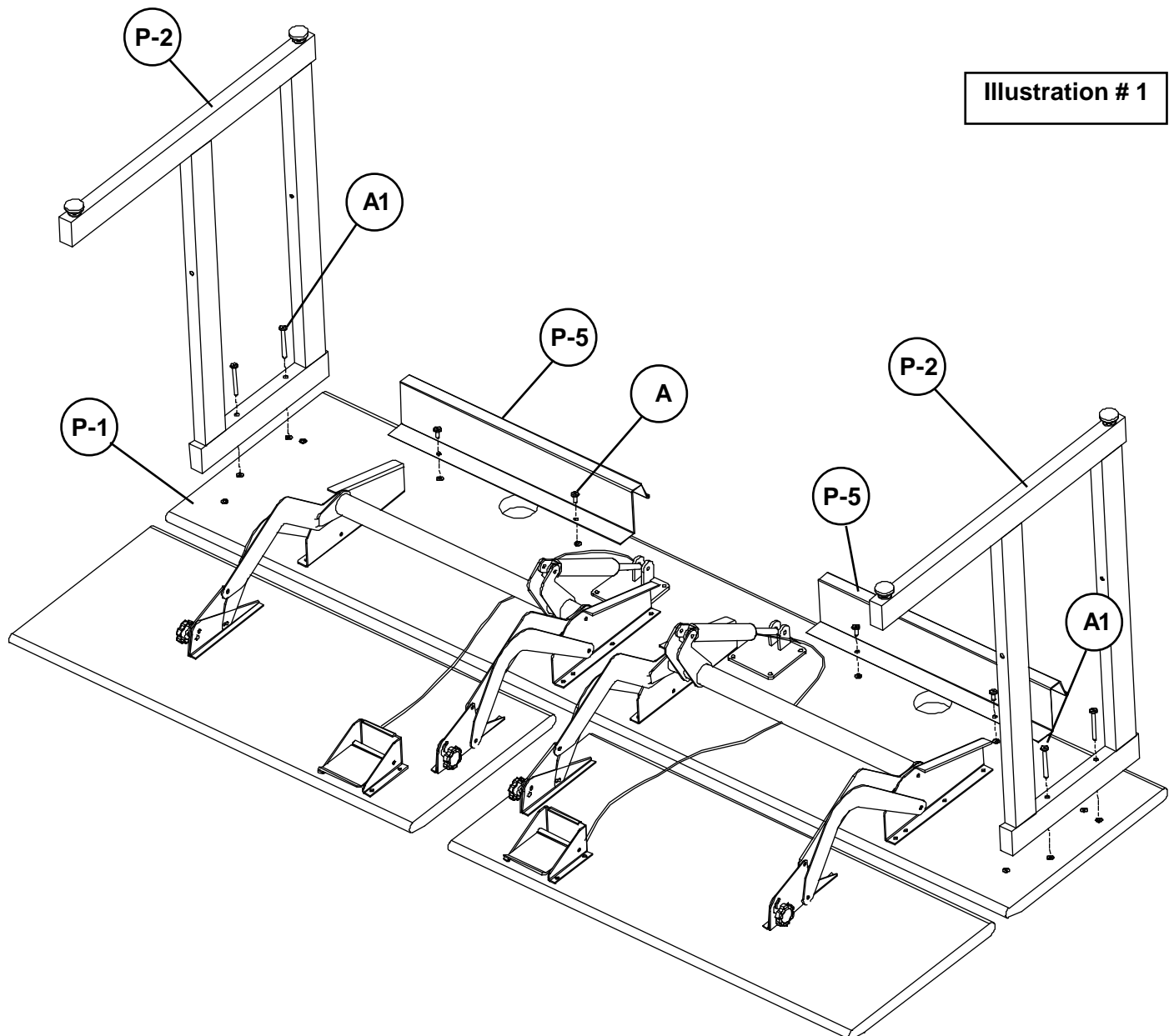
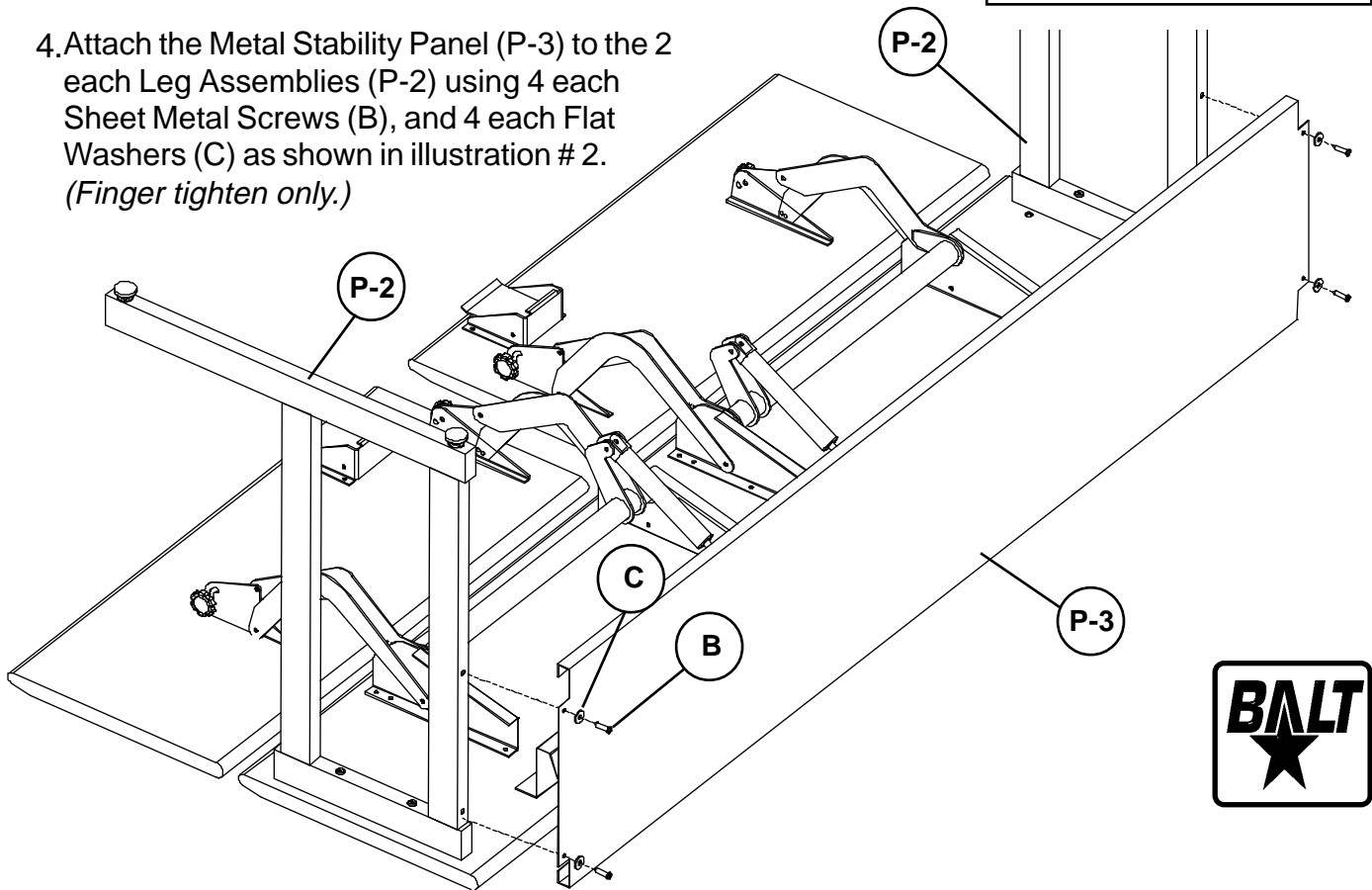

Illustration # 2

4. Attach the Metal Stability Panel (P-3) to the 2 each Leg Assemblies (P-2) using 4 each Sheet Metal Screws (B), and 4 each Flat Washers (C) as shown in illustration # 2.
(Finger tighten only.)



5. Attach 2 each Formed CPU Holders (P-4) to the the Top Platform w/Arms(P-1) using 4 each Flat Head screws (A) as shown in illustration # 3.

6. Secure the 2 Formed CPU Holders (P-4) to the 2 each Leg Assemblies (P-2) using 4 each Sheet Metal Screw (B).

(Tighten all Screws using Allen Wrench F & Phillips Head Screwdriver.)

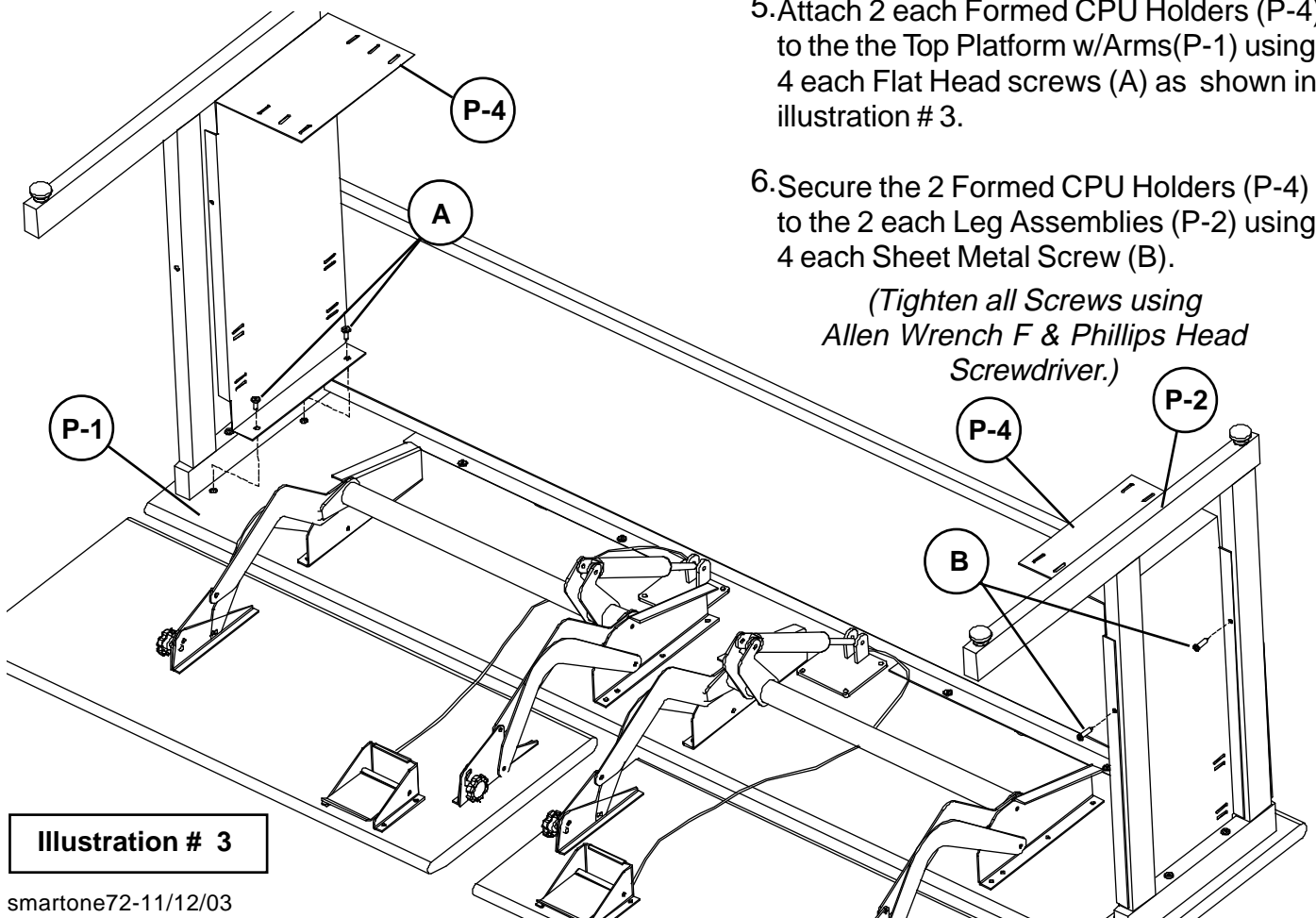
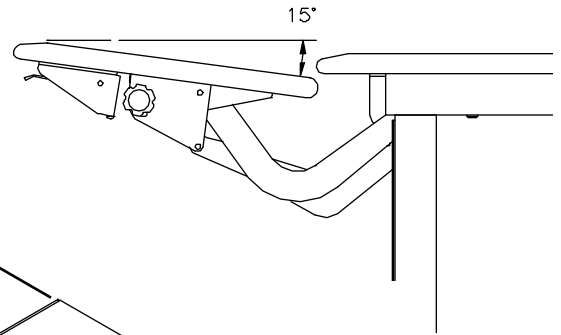
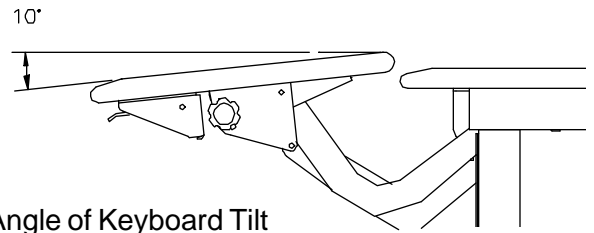

Illustration # 3

Smart-One 72 Dual Student Standup-Sit down Workstation



For more information
1-800-749-2258



Shipping Information
16.4 Cubic Feet
163 lbs.

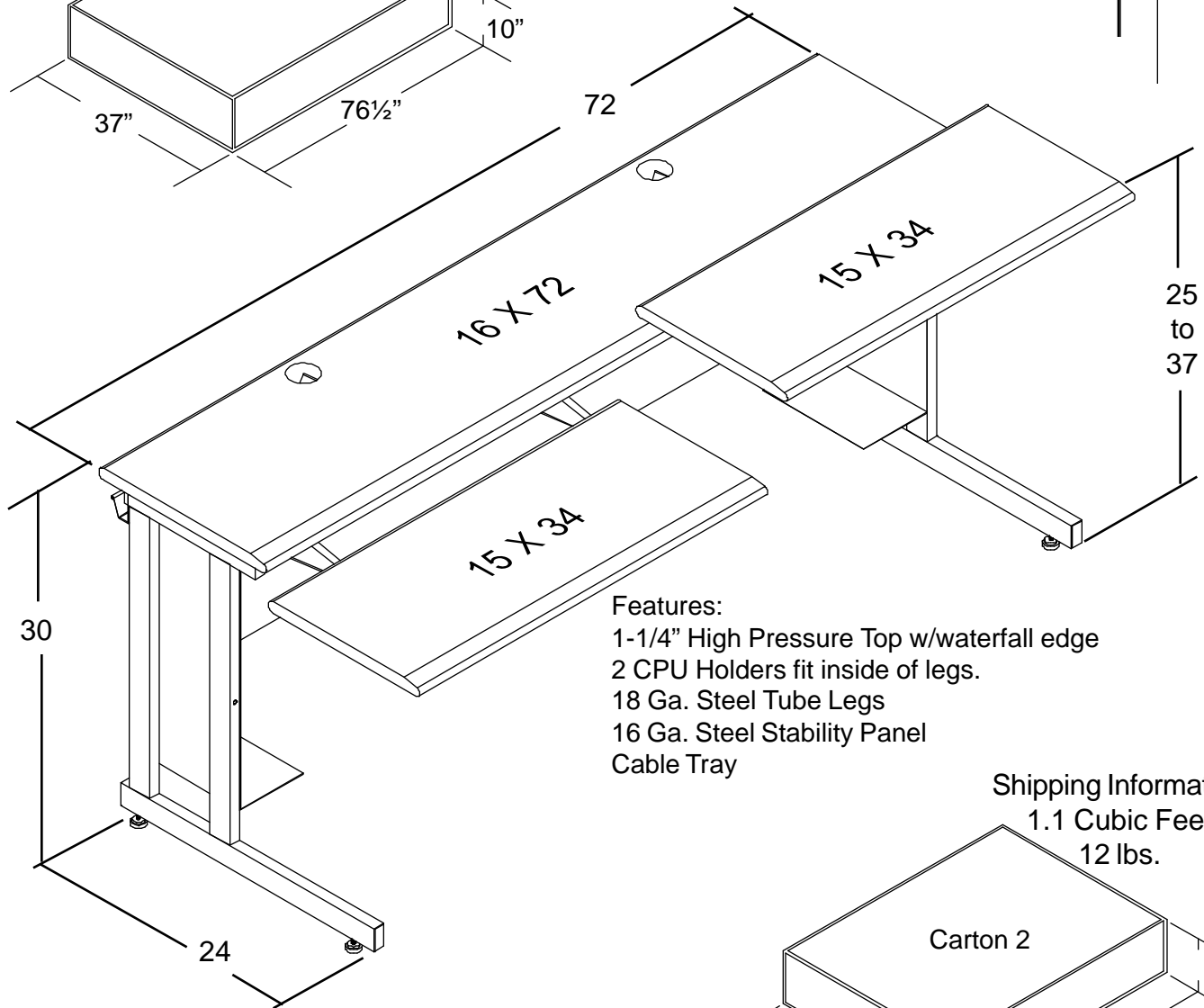
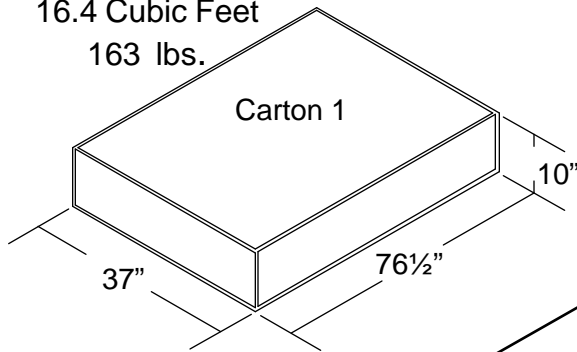

- Features:
- 1-1/4" High Pressure Top w/waterfall edge
 - 2 CPU Holders fit inside of legs.
 - 18 Ga. Steel Tube Legs
 - 16 Ga. Steel Stability Panel
 - Cable Tray

Shipping Information
1.1 Cubic Feet
12 lbs.

