

NetBook Carrier Specifications

Effective February 1, 2009

Introduction

The NetBook Carrier (NBC) provides a safe and easy way to transport 20, 26, 27, 30, 32 or 48 netbooks in a school, government, training, or corporate environment. The NBC provides storage and charges 30 mini netbooks. The dual entry capability of the NBC helps to ensure the security of stored equipment and timer configurations. The tambour door opening allows teachers and students to access the netbooks and other equipment while limiting access to the electrical components and timer, which can be accessed through the locking rear door panel by IT staff.



CSC-ML30, CSC-ML27X, CSC-ML48

Construction

Dividers

The NetBook Carrier (NBC) incorporates a unique Power Management Divider (PMD) which:

- Is constructed of a single piece of 20-gauge steel, spaced 1-7/8" apart and is removable to facilitate the storage of other devices when computer slots are not being used. Maximum brick thickness able to be stored between dividers is 1-7/8" wide.
- Incorporates a design conducive to airflow and assists with the dispersing of heat from the power supply and the netbooks.
- Provides a cord management solution by wrapping the netbook power supply cords around the divider to keep the cords neat and organized. This is done by removing the PMD from the NBC, placing the power supply on the PMD, wrapping the cords, and then securing the power supply and cords to the PMD with a plastic wire tie. The netbook cord is threaded through the top holes of the PMD so to hang in the appropriate location. The PMD is then inserted back into the NBC and the electrical plug is plugged into the power strip located inside the rear access panel.



CSC-CM20, CSC-CM26, CSC-CM32

NBC Body and Storage Compartment

- Venting design allows for natural convective airflow to aid in cooling when doors are closed and lateral airflow when doors are opened.
- Includes (2) 5" swivel foot brake casters and (2) 5" rigid casters.
- One (1) three point lock on the rear door limits access to electrical components and timer so IT configurations remain secure.
- Cord winders and grommets allow neat and organized cord management when moving the NBC cord winder and grommet holes (1-3/4" diameter) are mounted on the end of the NBC below the handle mounts.
- Consists of 16-gauge steel end uprights, 18-gauge steel base and shelves, 20-gauge steel back and side panels, and 14-gauge steel reinforced caster mounts.
- 100% of all painted steel components are powder coated finish, powder coating is the most environmentally safe coating method available today.



Bumpers

- Rubber corner bumpers extend beyond all surfaces of the NBC protecting the NBC as well as walls, doorways, and furniture.

Dimensions

• Dimensions excluding handle:

- CSC-ML30 - 30-1/4"W x 26-1/4"D x 37-7/8"H
- CSC-ML27X - 30-1/4"W x 26-1/4"D x 37-7/8"H
- CSC-ML48 - 43-3/16"W x 26-1/4"D x 37-7/8"H
- CSC-CM20 - 30-1/4"W x 26-1/4"D x 37-7/8"H
- CSC-CM26 - 35-7/8"W x 26-1/4"D x 37-7/8"H
- CSC-CM32 - 41-7/8"W x 26-1/4"D x 37-7/8"H

• Dimensions including handle:

- CSC-ML30 - 35-1/4"W x 26-1/4"D x 37-7/8"H
- CSC-ML27X - 35-1/4"W x 26-1/4"D x 37-7/8"H
- CSC-ML48 - 48-3/16"W x 26-1/4"D x 37-7/8"H
- CSC-CM20 - 35-1/4"W x 26-1/4"D x 37-7/8"H
- CSC-CM26 - 40-3/4"W x 26-1/4"D x 37-7/8"H
- CSC-CM32 - 46-3/4"W x 26-1/4"D x 37-7/8"H

• Netbook Compartment dimensions:

- CSC-ML30 - 2"W x 11-7/16"D x 8-1/16"H
- CSC-ML27X,ML48 - 2-3/16"W x 11-7/16"D x 8-1/16"H
- CSC-CM20,26,30 - 2"W x 11-7/16"D x 11-3/16"H

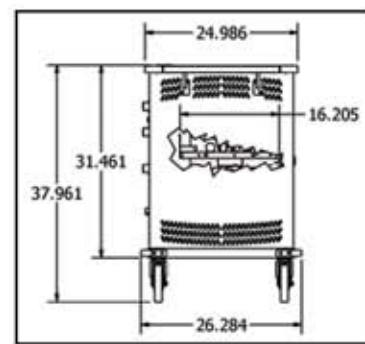
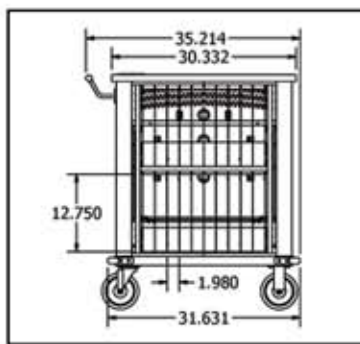

Laminate Top

- Durable 1-1/8" laminated wood top with T-molding allows for use of printers, projectors, and other equipment on top of the NBC.
- Provides a smooth work and writing surface, unobstructed by handles or metal lip.
- Grommet hole allows access to internal power outlets.
- Grommet can be replaced with optional Pop Up Power Center (PUPC).

Tambour Door

- Tambour door is constructed of 30mm wide and 12-1/2mm thick blue tint translucent grade PVC slats.
- Secured by 16-gauge black steel handles and lock hasp. Padlock is optional.
- Retractable tambour door design requires smaller footprint to open and close doors and provides easier access to store laptops than traditional hinged swinging doors.
- Translucent doors allow users to conduct visual inventory inspection of stored items, as well as charging status.
- Reinforced lock hasp.

Electrical Components

Timer Power Center (TPC)

- The NBC includes a double pole timer with lighted exterior on/off switch, circuit breaker protection, and 96 cycle/15 minute setting intervals. The NBC is UL & CA listed.
- NBC includes a combination of two (2) 10 or 16 bank electrical outlet units with power cord for charging laptops.
- Optional Pop-Up Power Center adds two additional outlets to the top of the cart.



Handle Assembly

- Positioned for teachers and students, the handle location provides an unobstructed work area on top of the NBC.
- Two (2) steel cord wraps (the lower portion of the handle assembly and the handle are used as cord wraps).
- Handle can be mounted on either side.
- A second handle option is available.

Shipping and Handling

	Est. Ship Wt.	Est. Product Wt.	Skid Dimensions
CSC-ML30	184	154	32"D x 36"W x 43-1/2"H
CSC-ML27X	184	154	32"D x 36"W x 43-1/2"H
CSC-ML48	238	208	32"D x 48"W x 43-1/2"H
CSC-CM20	184	154	32"D x 36"W x 43-1/2"H
CSC-CM26	206	176	32"D x 42"W x 43-1/2"H
CSC-CM32	238	208	32"D x 48"W x 43-1/2"H

All NBCs ship assembled (excluding handle) Freight Class 70 in one carton on a skid.

Warranty

Lifetime warranty on parts, limited 2 year warranty on tambour and electrical components. Warranty details are available upon request.