

TC35 / TC35FF

HEIGHT ADJUSTABLE PRESENTATION CART WITH AND WITHOUT POWER

PARTS LIST

Qty	Part#	Description	Ref	Qty
1	022-2479	Lower Left Front Leg	AA	24
1	022-2480	Lower Right Front Leg	BB	24
1	022-2481	Lower Left Rear Leg	CC	2
1	022-2482	Lower Right Rear Leg	DD	2
1	022-2474	Top Shelf	EE	4
1	022-2688	Middle Shelf	FF	4
1	010-4323	Bottom Shelf	GG	16
2	010-4777	Side Panels	HH	8
1	010-4778	Rear Panel	II	4
1	022-2689	Left Door	JJ	8
1	022-2690	Right Door		1
2	022-2477	Left Front & Right Rear Upper Legs		2
2	022-2478	Right Front & Left Rear Upper Legs		1
2	010-4780	Keyboard Shelves		
2	010-4779	Slide Brackets		
2	030-1191	14" Full Extension Slides		
2	015-0002	4" Casters w/o Lock		
2	015-0003	4" Casters w/ Lock		
1	CFPS	Electrical Unit - TC35FF ONLY		

HARDWARE LIST

Part#	Description
030-0300	5/8" Square Head Bolts
030-0002	5/16"-18 Serrated Nuts
030-0023	#6-32 x 3/8" Machine Screws
030-0522	#6-32 Hex Nuts w/ External Teeth
030-0383	#10 x 1/2" Truss Head Screws
030-0325	1/4-20 x 1/2" Combo Screws
030-1228	#8-32 x 1/4" Truss Screws
030-1203	#8-32 Acorn Nuts
030-0255	#10 x 5/8" Phillips Pan Hd Screws
02236	8-32 Hex Flange Nuts
010-1188	Bottom Door Stop
012-0286	Plastic Handles
010-1106	Hex Wrench

TOOLS REQUIRED

Hex Wrench (Provided)
Phillips Screwdriver
Rubber Mallet (Optional)

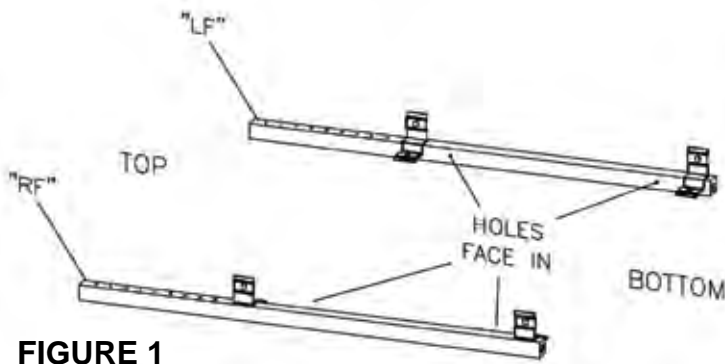

FIGURE 1

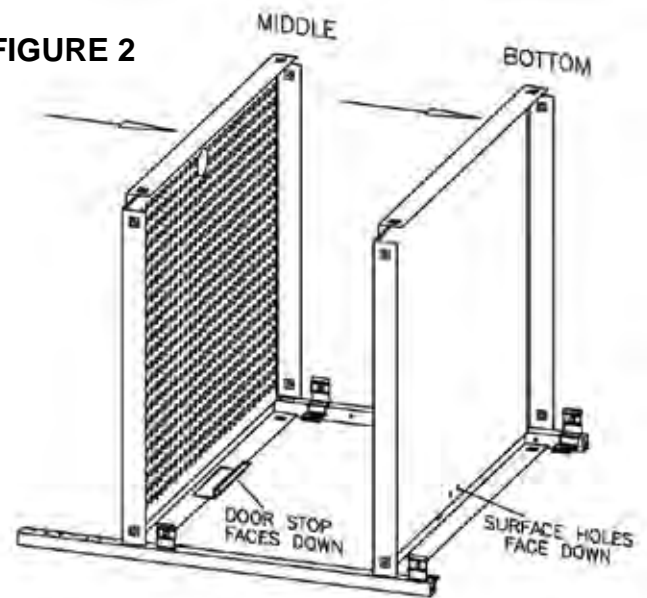
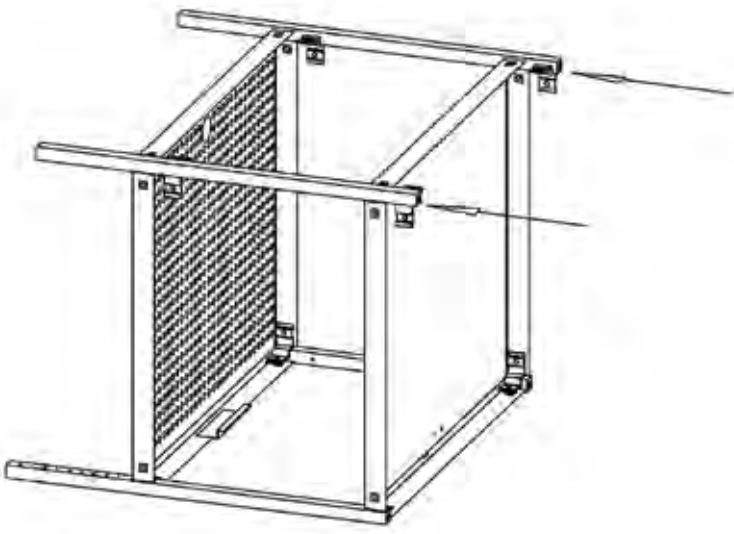

FIGURE 2

STEP 1

Position the lower front legs (stamped "LF" and "RF") with the brackets facing up and in as shown in **FIGURE 1**. Slide the bottom and middle shelves onto the legs making sure the brackets are inside of the shelves as shown in **FIGURE 2**.



STEP 2

Slide the 2 remaining lower legs onto the shelves as shown. Make sure the brackets are inside the shelves.

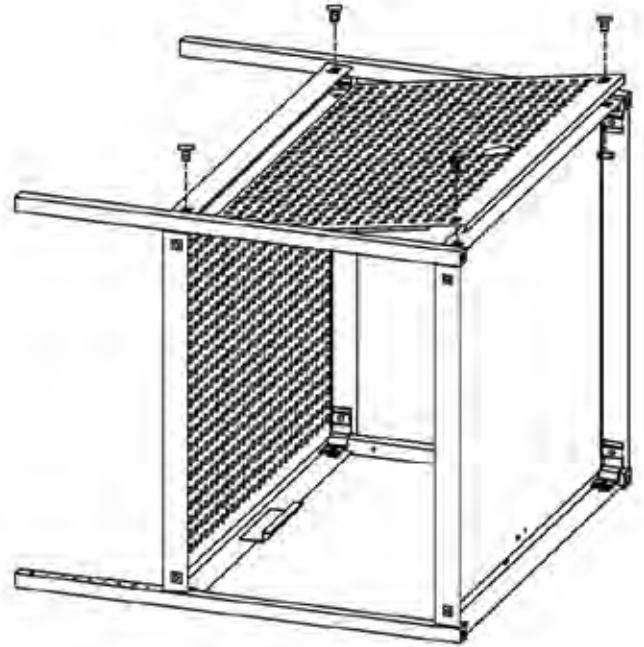

STEP 3

Slide the rear panel between the middle and bottom shelf so that the top flange is behind the leg brackets and the bottom hooks onto the bottom shelf. Attach in the 4 corners with bolts (AA) and nuts (BB) as shown.

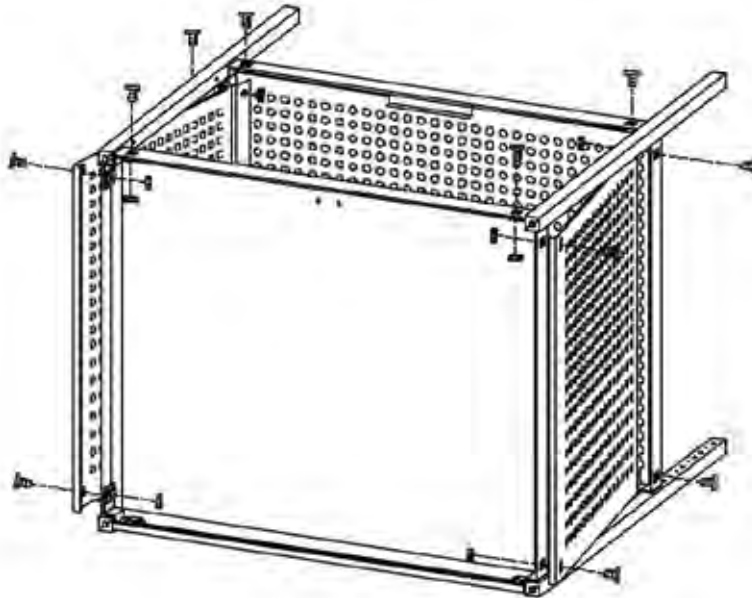
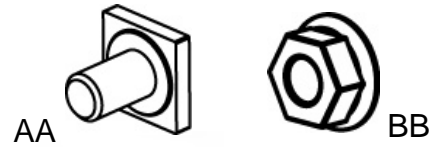

STEP 4

CAREFULLY turn the unit on its back. Attach each side panel in the same manner as described in STEP 3 using bolts (AA) and nuts (BB) as shown.

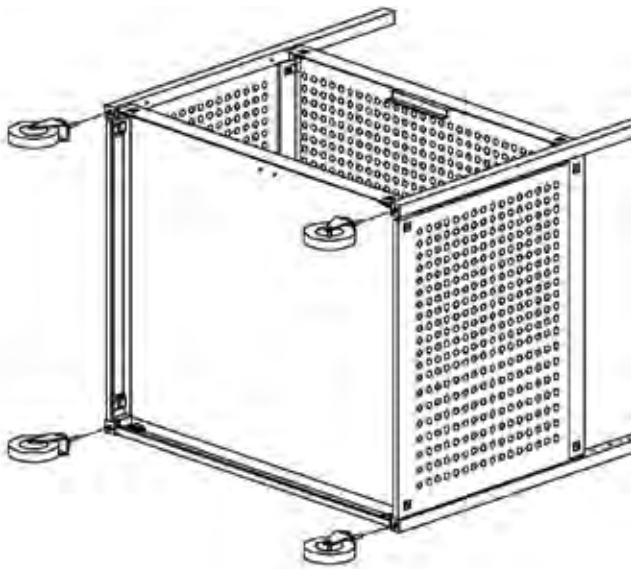

STEP 5

Push casters into the sockets of each leg. To ensure casters are secure in sockets, a rubber mallet may be used to tap casters in place.

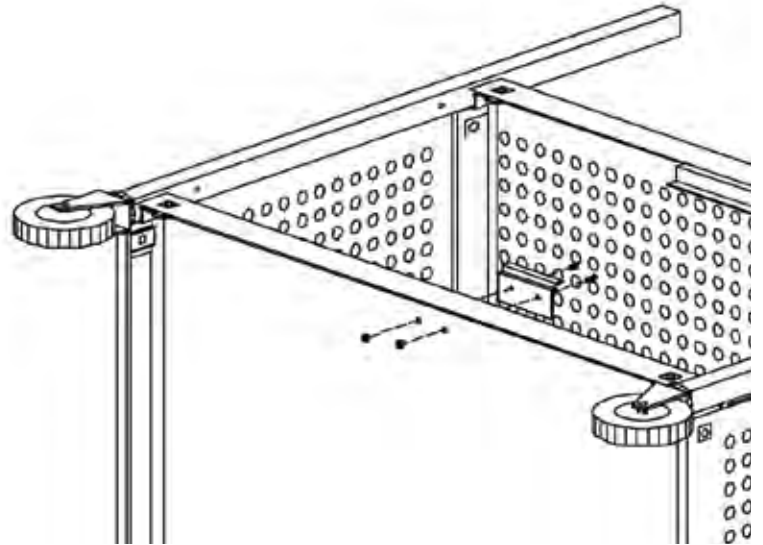

STEP 6

Attach door stop to bottom shelf using screws (CC) and nuts (DD). **CAREFULLY** stand unit upright.

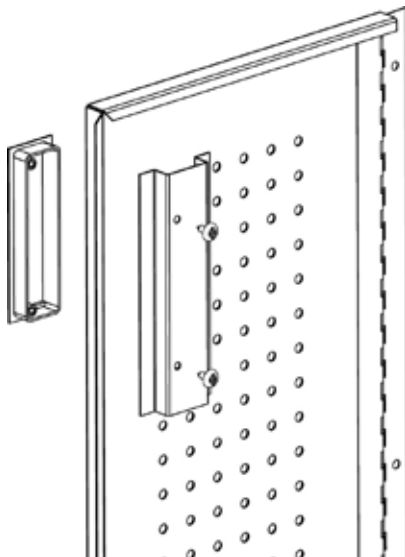
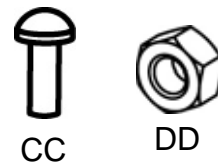

STEP 7

Attach the door handles using screws (EE).

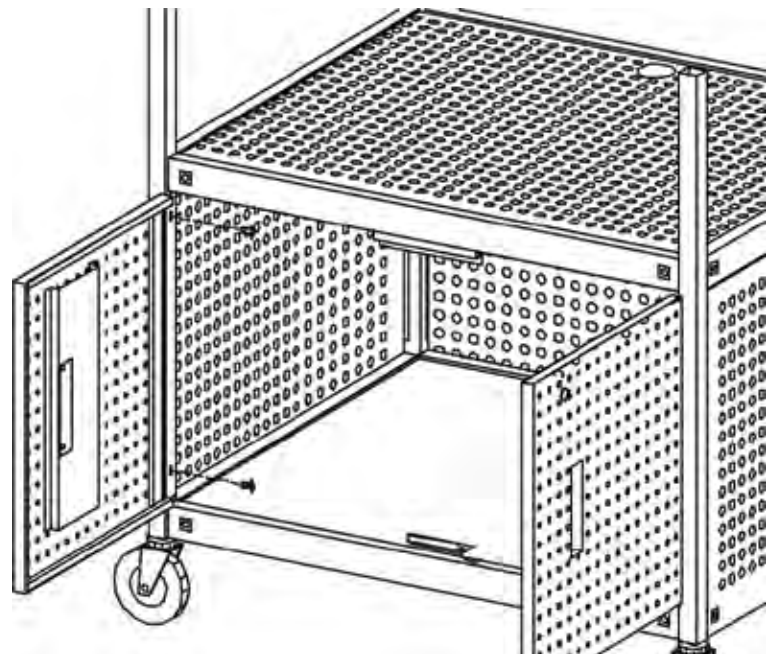

STEP 8

Attach the doors (right one has lock) between the middle and bottom shelves with screws (FF) as shown. **NOTE:** Adjustments to the door stop may need to be done.



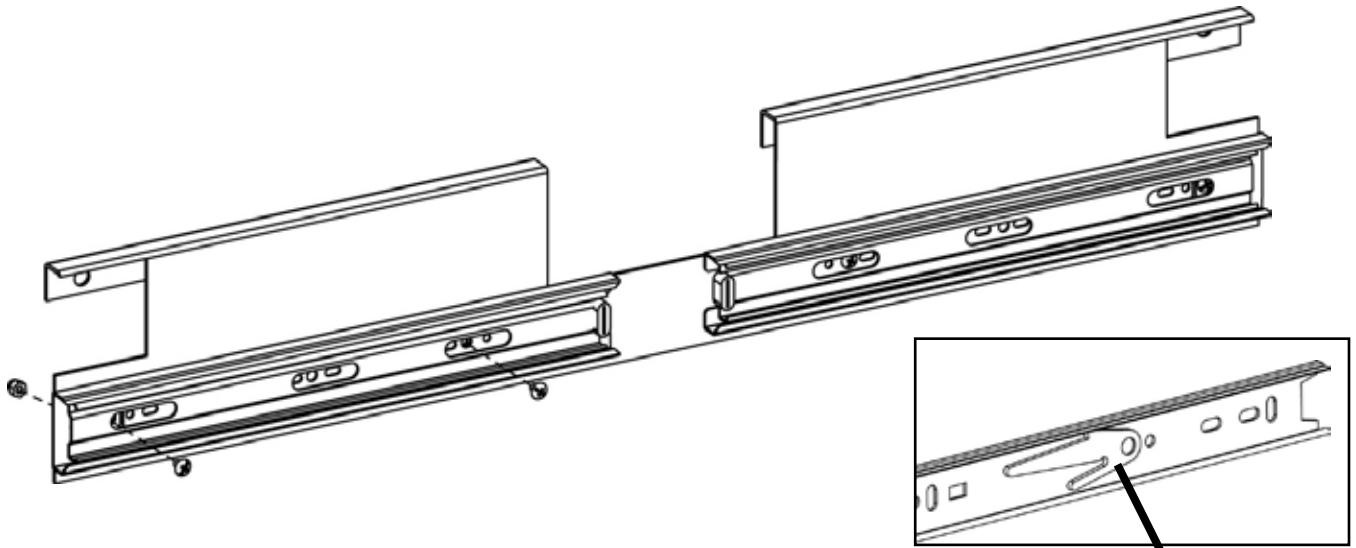

NOTE: Separate slides by pulling on black tab.

STEP 9

Separate each slide and attach outer slide piece (2 per bracket) to the slide brackets using screws (GG) and nuts (HH) as shown. **NOTE:** Slide may need to be extended some to align attachment holes.

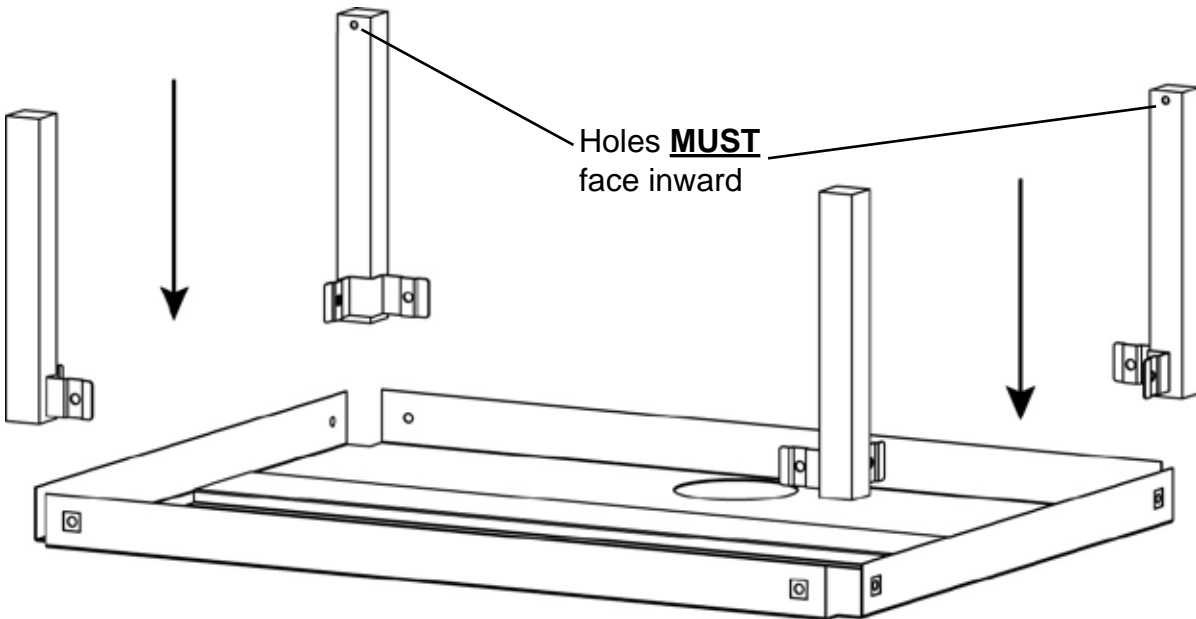

STEP 10

Lay top shelf down and slide upper legs into each corner as shown. **NOTE:** Make sure all holes face inward.

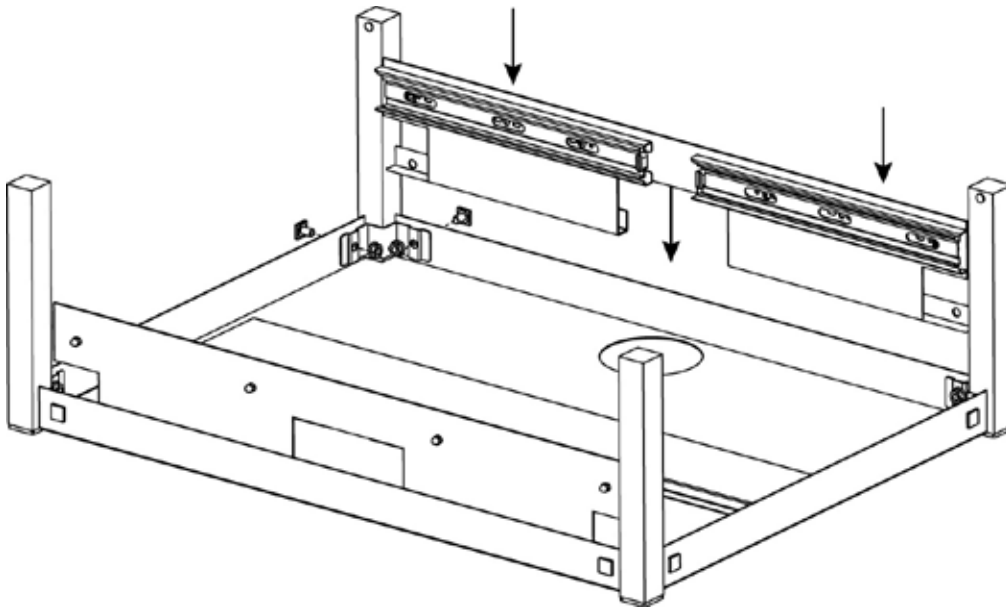

STEP 11

Slide each slide bracket down between legs as shown. Secure all 4 corners with screws (AA) and bolts (BB). **NOTE:** The flange on the slide bracket is positioned in front of the w-bracket on the leg.

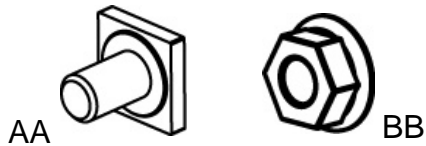

Assembled Position

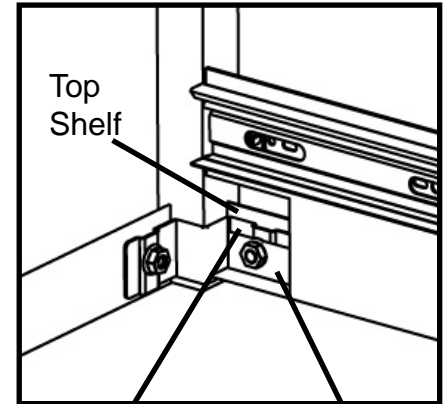

Top Shelf
W-Bracket
Bracket Flange

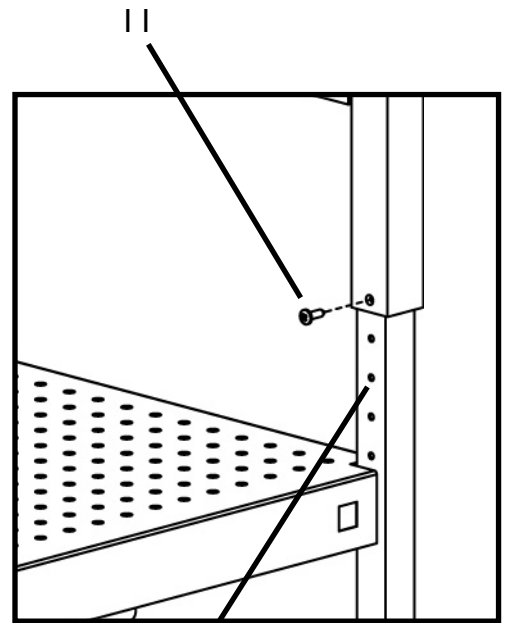
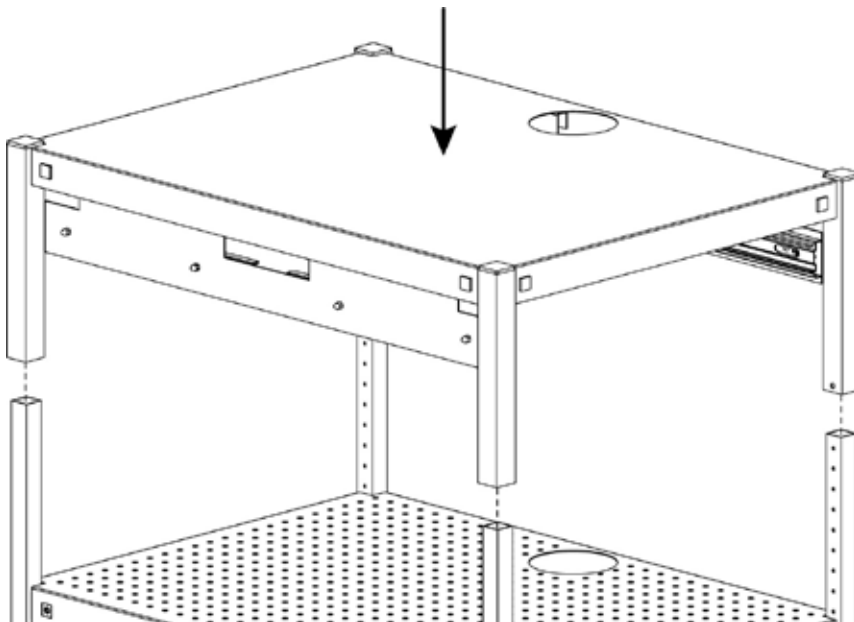

Upper assembly is height adjustable and can be mounted in any of these holes.

STEP 12

Slide upper assembly onto lower legs and secure together with screws (II). **NOTE:** The upper assembly is adjustable and can be positioned in any of the lower leg holes.



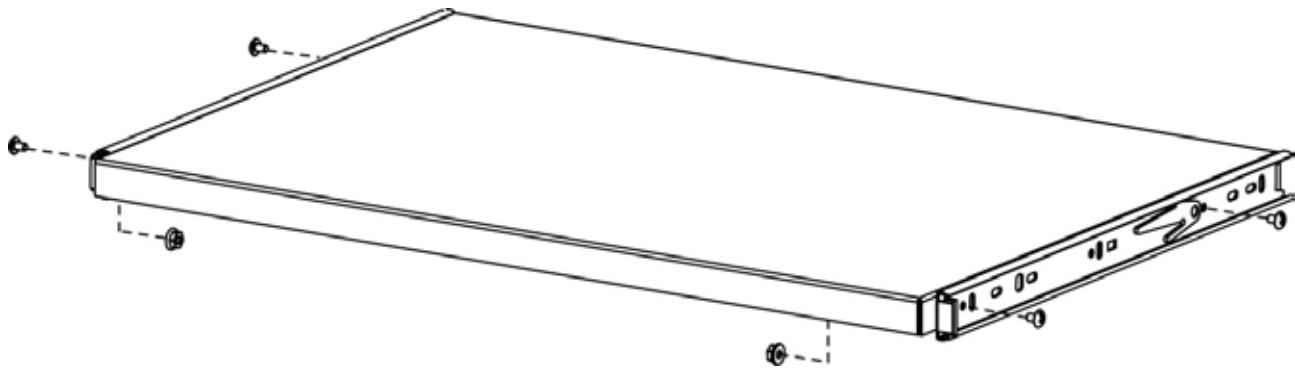

STEP 13

Attach inner slide piece to keyboard shelf with screws (GG) and nuts (JJ).

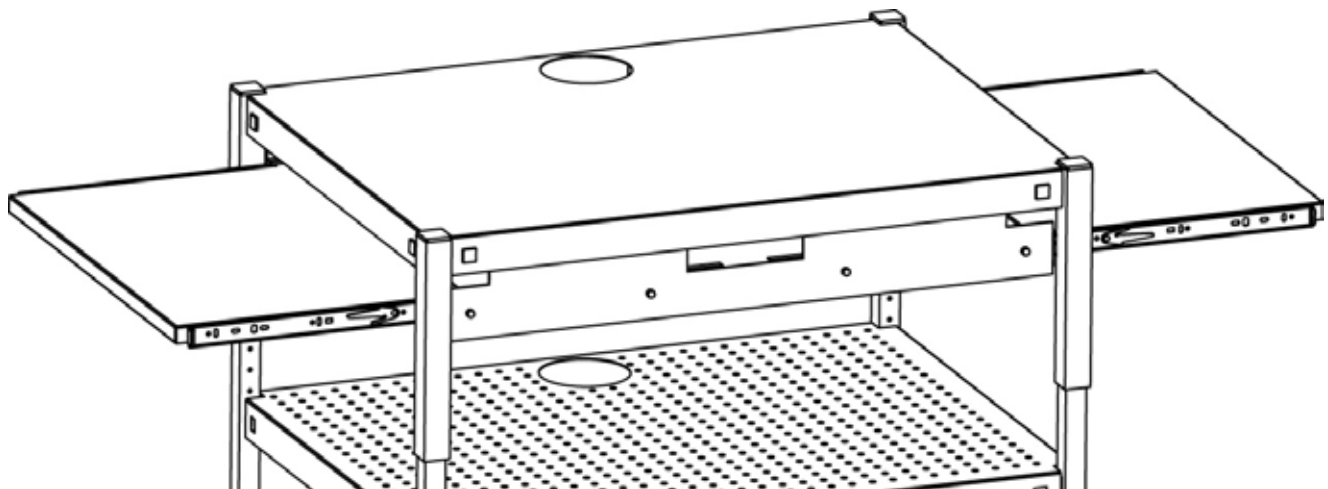

STEP 14

Slide each keyboard shelf into each side of the cart.

Bretford
11000 Seymour Avenue
Franklin Park, IL 60131
TEL: 847.678.2545
800.521.9614
FAX: 847.678.0852
800.343.1779

Bretford Ltd.
2 Etongate
110 Windsor Road, Slough
Berkshire SL1 2JA England
TEL: 011 44 17 5353 9955
FAX: 011 44 17 5353 9478