



KRAMER ELECTRONICS, Ltd.

USER MANUAL

Kramer Distributor **TOOLS**

Models:

103AV, 104M, 105A, 105S, 105V, 105VB

IMPORTANT: Before proceeding, please read paragraph entitled
"Unpacking and Contents"



Table Of Contents

Section	Name	Page
1	INTRODUCTION	1
1.1	A Word on Video/Audio Distributors	1
1.2	Factors Affecting Quality of Results	1
2	SPECIFICATIONS	2
3	HOW DO I GET STARTED?	4
4	UNPACKING AND CONTENTS	4
4.1	Optional Accessories	4
5	VIDEO/AUDIO DISTRIBUTORS	5
5.1	Getting to Know Your 103AV Distributor	5
5.2	Getting to Know Your 104M Distributor	6
5.3	Getting to Know Your 105A Distributor	7
5.4	Getting to Know Your 105S Distributor	8
5.5	Getting to Know Your 105V Distributor	9
5.6	Getting to Know Your 105VB Distributor	10
6	TYPICAL APPLICATIONS	11
6.1	Typical Video Distribution	11
6.2	Increasing the Number of Outputs	11
6.3	Increasing the Number of Inputs	12
6.4	Combined Audio and Video Distribution	13
6.5	Line Amplification	13
6.6	Image Enhancement	15
7	INSTALLATION	16
7.1	Rack Mounting	16
8	CONNECTING TO VIDEO DEVICES	16
9	CONNECTING TO AUDIO DEVICES	16
10	USING THE MACHINES	16
10.1	Powering on the Machine	16
10.2	Gain Control (103AV, 105V, 105VB only)	16
10.3	Luma Control (105S only)	16
10.4	Chroma Control (105S only)	17
10.5	Audio Level Control (103AV, 104M, 105A only)	17
11	TAKING CARE OF YOUR MACHINE	17
12	TROUBLESHOOTING	17
12.1	Power and Indicators	17
12.2	Video Signal	19
12.3	Audio Signal	19

List Of Illustrations

Figure		Page
1	103AV Panel Features	5
2	104M Panel Features	6
3	105A Panel Features	7
4	105S Panel Features	8
5	105V Panel Features	9
6	105VB Panel Features	10
7	Typical Video Distribution	11
8	Cascading the Amplifiers	12
9	Increasing the Number of Inputs	12
10	Combined Audio and Video Distribution	13
11	Typical Line Amplification	14
12	Image Enhancement	15
13	Fuse Locations	18

List Of Tables

Table		Page
1	103AV Panel Features	5
2	104M Panel Features	6
3	105A Panel Features	7
4	105S Panel Features	8
5	105V Panel Features	9
6	105VB Panel Features	10



1 INTRODUCTION

Congratulations on your purchase of this Kramer Electronics Distributor. Since 1981 Kramer has been dedicated to the development and manufacture of high quality video/audio equipment. The Kramer line has become an integral part of many of the best production and presentation facilities around the world. In recent years, Kramer has redesigned and upgraded most of the line, making the best even better. Kramer's line of professional video/audio electronics is one of the most versatile and complete available, and is a true leader in terms of quality, workmanship, price/performance ratio and innovation. In addition to the Kramer line of high quality distributor, such as the one you have just purchased, Kramer also offers a full line of high quality switchers, processors, interfaces, controllers and computer-related products. This manual includes configuration, operation and option information for the following products from the Kramer line of distributor **TOOLS**. All these **TOOLS** are similar in operation and features.

- 103AV - 1:3 Video/Audio Distributor
- 104M - 1:4 Microphone Amplifier
- 105A - 1:5 Audio Distributor
- 105S - 1:5 s-Video Distributor
- 105V - 1:5 Video Distributor
- 105VB - 1:5 Video Distributor

1.1 A Word on Video/Audio Distributors

Video/Audio Distributors described in this manual, distribute one signal to several users. They vary in the number of outputs, operating format and bandwidth. Video/Audio Distributors are used to distribute one source to several acceptors (monitors, audio devices etc.) for simultaneous recording or monitoring of one source, with no discernible signal degradation. A good quality distributor amplifies the incoming signal, pre-compensates the signal for potential losses (resulting from the use of long cables, noisy source, etc.) and generates several identical buffered and amplified outputs. Often, a signal processor is inserted between the source and the distributor for correction and fine tuning of the source signal before multiplication, so that all copies are corrected in the same way. The front panels of these Kramer Distributors are designed to be simple to operate. Typical applications of the machines are: audio/video duplication, studios delivering undiminished quality duplicates and video showrooms delivering an identical signal to several acceptors.

1.2 Factors Affecting Quality of Results

There are many factors affecting the quality of results when signals are transmitted from a source to an acceptor:

- **Connection cables** - Low quality cables are susceptible to interference, they degrade signal quality due to poor matching and cause elevated noise levels. They should therefore be of the best quality.
- **Sockets and connectors of the sources and acceptors** - So often ignored, they should be of highest quality, since "Zero Ohm" connection resistance is the target. Sockets and connectors also must match the required impedance (75ohm in video). Cheap, low quality connectors tend to rust, thus causing breaks in the signal path.
- **Amplifying circuitry** - Must have quality performance when the desired end result is high linearity, low distortion and low noise operation.
- **Distance between sources and acceptors** - Plays a major role in the final result. For long distances (over 15 meters) between sources and acceptors, special measures should be taken in order to avoid cable losses. These include using higher quality cables or adding line amplifiers.
- **Interference from neighboring electrical appliances** - These can have an adverse effect on signal quality. Balanced audio lines are less prone to interference, but unbalanced audio should be installed far from any mains power cables, electric motors, transmitters, etc. even when the cables are shielded.



2 SPECIFICATIONS

	103AV	104M	105A
Configuration	1:3	1:4	1:5
Input Type	1 composite video stereo - audio	1 One mono microphone	1 stereo-audio/balanced mono
Input Connections	Video: RCA connector Audio: 3.5mm mini phone connector	6.5mm phone connector	3.5mm mini phone connector
Input Level	Video: 1Vpp/ 75ohm Audio: 1Vpp/33kohm	5mVpp/10Kohm	1Vpp/33kohm
Output Type	3 composite video 3 stereo - audio	4 mono line level	5 stereo-audio/balanced mono
Output Connector	Video: RCA connectors Audio: 3.5mm mini phone connectors	6.5mm phone connectors	3.5mm mini phone connectors
Output Level	Video: 1Vpp/75ohm Audio: 1Vpp/50ohm	1Vpp/150ohm	1Vpp/50ohm
Level Control	Video: -2dB to +4dB Audio: 0 to +6dB	5dB to 54dB	0 to +3.5dB
Output Coupling	AC	AC	AC
Video Bandwidth	320MHz, -3dB	NA	NA
K-factor	<0.1%	NA	NA
Differential Phase	0.16Deg.	NA	NA
Differential Gain	0.1%	NA	NA
Video S/N Ratio	72dB	NA	NA
Max. Output Level	2Vpp (video) 5Vpp (audio)	4.8Vpp	5Vpp
Crosstalk	-70dB @20kHz	NA	NA
Audio Bandwidth	20-20kHz, -2dB	20-37kHz	20kHz, 0.1 dB
Audio THD+Noise	0.02%	<0.1%	< 0.03%
Audio S/N Ratio	85dB unweighted	Better than 78dB	80dB unweighted
Accessories	Power supply, mounting bracket	Power supply, mounting bracket	Power supply, mounting bracket
Options	Model VA-50P rack mountable power supply with six 12VDC outlets	Model VA-50P rack mountable power supply with six 12VDC outlets	Model VA-50P rack mountable power supply with six 12VDC outlets
Dimensions (W, D, H)	12 x 7.5 x 2.5 (cm) 4.7" x 2.9" x 1"	12 x 7.5 x 2.5 (cm) 4.7" x 2.9" x 1"	12 x 7.5 x 2.5 (cm) 4.7" x 2.9" x 1"
Weight	0.28kg. (0.6lbs.) Approx.	0.28kg. (0.6lbs.) Approx.	0.28kg. (0.6lbs.) Approx.
Power Consumption	1.2VA	0.24VA	1.2VA
Power Source	12VDC, 100mA	12VDC, 20mA	12VDC, 100mA



SPECIFICATIONS (continued)

	105S	105V	105VB
Configuration	1:5	1:5	1:5
Input Type	1 S-video	1 video	1 video
Input Connections	4P connector	RCA connector	BNC connector
Input Level	1Vpp/75ohm (Y), 0.3Vpp/75ohm (C)	1Vpp/75ohm	1Vpp/75ohm
Output Type	5 S-video	5 video	5 video
Output Connector	4P connectors	RCA connectors	BNC connectors
Output Level	1Vpp/75ohm (Y), 0.3Vpp/75ohm (C)	1Vpp/75ohm	1Vpp/75ohm
Level Control	Luma: +1dB to +3dB Chroma: 0.2dB to +2dB	-0.5dB to +4dB	-0.5dB to +4dB
Output Coupling	AC	AC	AC
Video Bandwidth	230MHz, -3dB (Y)	280MHz, -3dB	280MHz, -3dB
K-factor	<0.05%	<0.05%	<0.05%
Differential Phase	0.12Deg.	0.15Deg.	0.1Deg.
Differential Gain	0.08%	0.1%	0.1%
Video S/N Ratio	72dB	75dB	80dB
Max. Video Output	2Vpp (Y)	2Vpp	2Vpp
Accessories	Power supply, mounting bracket	Power supply, mounting bracket	Power supply, mounting bracket
Options	Model VA-50P rack mountable power supply with six 12VDC outlets	Model VA-50P rack mountable power supply with six 12VDC outlets	Model VA-50P rack mountable power supply with six 12VDC outlets
Dimensions (W, D, H)	12 x 7.5 x 2.5 (cm) 4.7" x 2.9" x 1"	12 x 7.5 x 2.5 (cm) 4.7" x 2.9" x 1"	12 x 7.5 x 2.5 (cm) 4.7" x 2.9" x 1"
Weight	0.28kg. (0.6lbs.) Approx.	0.28kg. (0.6lbs.) Approx.	0.32kg. (0.7bs.) Approx.
Power Consumption	1.2VA	1.2VA	1.2VA
Power Source	12 VDC, 100mA	12 VDC, 100mA	12 VDC, 100mA



3 HOW DO I GET STARTED?

The fastest way to get started is to take your time and do everything right the first time. Taking 15 minutes to read the manual may save you a few hours later. You don't even have to read the whole manual. If a section doesn't apply to you, you don't have to spend your time reading it.

4 UNPACKING AND CONTENTS

The items contained in your Kramer Distributor package are listed below. Please save the original box and packaging materials for possible future transportation and shipment of the accessory.

Distribution Amplifier	Kramer Concise Product Catalog
Power Supply (12VDC)	Mounting Brackets
User Manual	4 Rubber Feet

4.1 Optional Accessories

The following accessories, which are available from Kramer, can enhance implementation of your distributor. For information regarding cables and additional accessories, contact your Kramer dealer.

- **Rack Adapter** - Used to install smaller size machines in a standard 1U rack. One or more machines may be installed on each adapter.
- **BNC "Y" Connector** - Used for looping purposes and splits the incoming signal to enable connection of an additional machine.
- **Termination Plug** - Used to terminate the line to 75ohm for proper matching.
- **SP-11** - (Video/Audio Processor) can be serially connected between the video/audio source and the distribution amplifier for video and audio control/correction. The machine provides camera control and luminance/white balance correction. The SP-11 is also capable of performing composite to Y/C conversion and bi-directional transcoding. The machine allows full control over the video signal: video gain down to full fade, log or linear definition control, log or linear contrast control, color saturation control, black level control, red, green and blue controls and a screen splitter control for "before-after" comparison. The Input switch control is "audio-follow-video".
- **104L** - (Video Line Amplifier) can be serially connected between the video source and the distribution amplifier for video processing, the machine is used for video line amplification and cable compensation, video field work and SDI signal distribution. Signal loss and the resulting depreciation in picture quality is a real problem in any video setup requiring considerable distance between video source and acceptors. The KRAMER 104L video Line Amplifier, one of the KRAMER **TOOLS**, is a high quality amplifier, which prevents video signal losses over long cables. For best results the 104L amplifier is installed adjacent to the video source. The 104L is housed in the compact KRAMER **TOOLS** enclosure and is fed by a 12VDC source. High bandwidth and front accessible controls make it suitable for the most demanding analog and SDI studio applications.
- **4x1VB** - (4x1 mechanical switcher) can be serially connected between the composite video sources and the distribution amplifier for video switching. It is designed for composite video signals using BNC connectors. It accepts up to four inputs and allows the user to select any input to be routed to one output using buttons located on the side panel. High quality switching components are used to ensure minimal crosstalk and very high bandwidth. The entirely passive design of the **4x1VB** eliminates the need for a power supply. Unselected inputs are automatically terminated into a 75ohm resistor. The **4x1VB** is part of the Kramer **TOOLS** family of compact, high quality, cost effective solutions for a variety of applications.
- **VS-801xl**- (8x1 Composite/Single Component Video & Unbalanced Audio Switcher) allows for several video/audio sources to be connected to its inputs for switching. The machine provides truly effortless switching between eight video and unbalanced audio inputs and one output. Switching is done during vertical interval, either of source no. 1 or of the video available on the external sync socket. The switcher may be controlled by touch buttons or by contact closure via a remote socket on the back of the machine. Video signal bandwidth is 225MHz (typical), allowing the machine to be used in the most demanding applications.
- **VIDEO TESTER** - A new, unique, patented, indispensable tool for the video professional, the video Tester is used to test a video path leading to/from an amplifier. By pressing only one touch switch it can trace missing signals, distinguish between good and jittery (VCR sourced) signals, and identify the presence of good signals. Whenever a video signal is missing, because of bad connections, cable breaks or faulty sources, the video Tester is all you need.



5 VIDEO/AUDIO DISTRIBUTORS

This section describes all the controls and connections of your distributor. Understanding all of the controls and connections helps you realize the full power of your distributor.

5.1 Getting to Know Your 103AV Distributor

The Kramer 103AV is a high performance 1x3 distribution amplifier for composite video and stereo-audio signals. Video bandwidth of 320MHz ensures that the 103AV remains transparent even in the most critical applications. The 103AV accepts a single input and distributes it to three identical outputs using RCA connectors for video, and 3.5mm phone connectors for stereo - audio. A 12VDC power supply is provided for typical operation, but the optional VA-50P can power up to six Kramer devices requiring 12VDC. The 103AV is part of the Kramer **TOOLS** family of compact, high quality, and cost effective solutions for a variety of applications.

Panel features of the 103AV are described in Figure 1 and Table 1.

NOTE

For operation instructions refer to section 11.

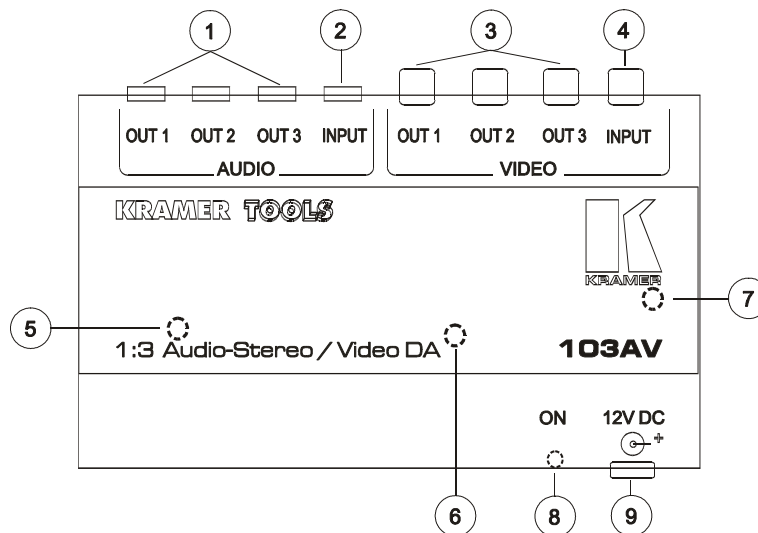

Figure 1: 103AV Panel Features

Table 1: 103AV Panel Features

No.	Feature	Function
1.	AUDIO OUT 1- OUT 3 mini phone connectors	3 amplified and buffered audio outputs.
2.	AUDIO INPUT mini phone connector	Audio input.
3.	VIDEO OUT 1- OUT 3 RCA connectors	3 amplified and buffered video outputs.
4.	VIDEO INPUT RCA connector	Video input.
5.	L trimmer	Adjusts the left channel audio gain.
6.	R trimmer	Adjusts the right channel audio gain.
7.	GAIN trimmer	Adjusts the gain of the video outputs.
8.	ON Led	Illuminates when the machine is powered.
9.	12VDC feed connector	A DC connector that allows power to be supplied to the unit.



5.2 Getting to Know Your 104M Distributor

The Kramer **104M** is a simple, high quality 1x4 microphone distribution amplifier. It accepts a single Mic input which is amplified and split to four identical outputs using ¼" TRS connectors. A recessed control is provided on the side panel to set the output level. By setting an internal jumper, phantom power can be applied to the input for use with compatible condenser microphones. A 12VDC power supply is provided for typical operation, but the optional **VA-50P** can power up to six Kramer devices requiring 12VDC. The **104M** is part of the Kramer **TOOLS** family of compact, high quality, and cost effective solutions for a variety of applications.

Panel features of the **104M** are described in Figure 2 and Table 2.

NOTE

For operation instructions refer to section 11.

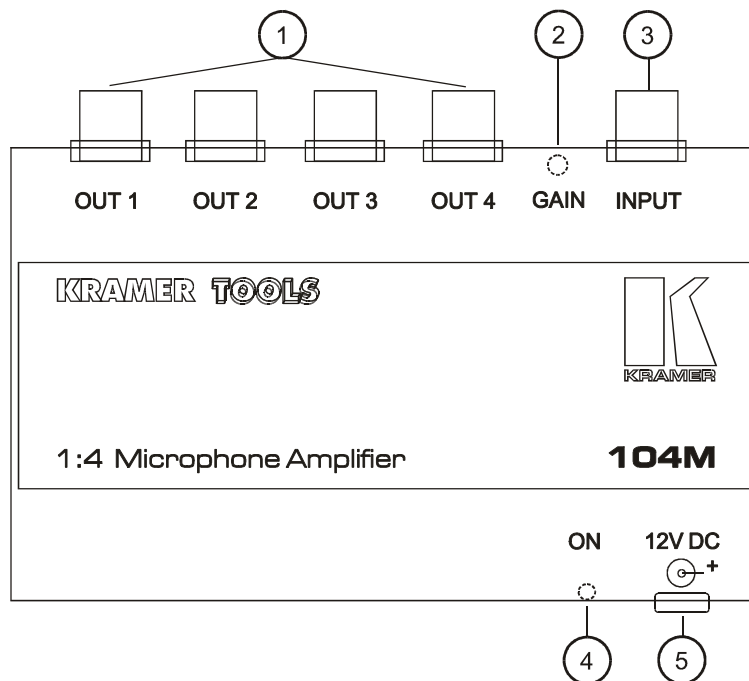

Figure 2: 104M Panel Features

Table 2: 104M Panel Features

No.	Feature	Function
1.	OUT 1- OUT 4 phone connectors	4 amplified and buffered audio outputs.
2.	GAIN trimmer	Controls the audio output level.
3.	INPUT phone connector	Mono microphone audio input.
4.	ON Led	Illuminates when the machine is powered.
5.	12VDC feed connector	A DC connector that allows power to be supplied to the unit.



5.3 Getting to Know Your 105A Distributor

The Kramer 105A is a high performance 1x5 distribution amplifier for stereo - audio signals. It accepts one stereo input and distributes the signal to five identical outputs using 3.5mm mini jacks. Separate gain controls for left and right channels allow the user to adjust the output level. The 105A is typically used for unbalanced stereo - audio sources such as VCR's, portable cassette and CD players, computer sound cards, etc., but can also distribute a balanced mono signal using adapter cables made from parts available at most electronic component stores. The 105A is the perfect companion to Kramer video distribution amplifiers like the 105V, 105VB, etc. A power supply is included for typical operation. The 105A is part of the Kramer **TOOLS** family of compact, high quality, and cost effective solutions for a variety of applications.

Panel features of the 105A are described in Figure 3 and Table 3.

NOTE

For operation instructions refer to section 11.

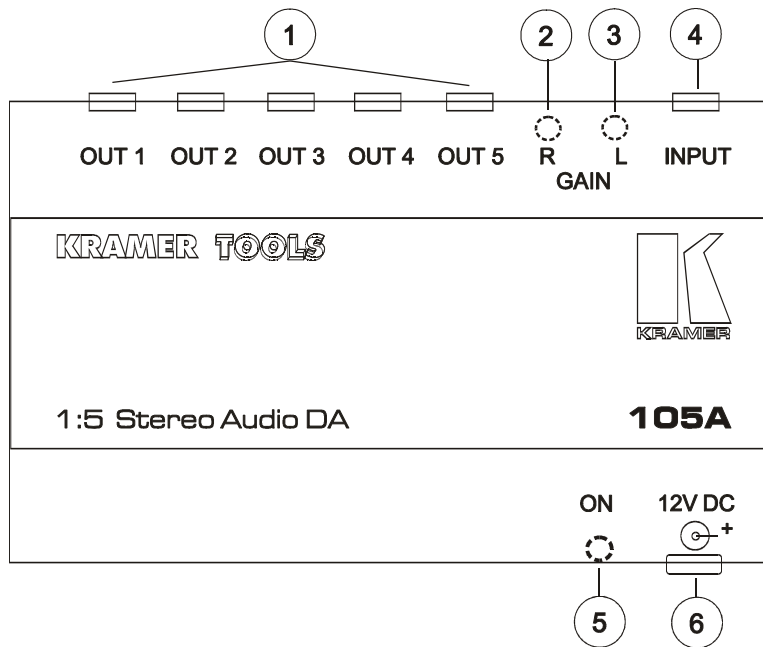

Figure 3: 105A Panel Features

Table 3: 105A Panel Features

No.	Feature	Function
1.	OUT 1- OUT 5 mini phone connectors	5 amplified and buffered audio outputs.
2.	R GAIN trimmer	Controls the gain of the right channel output.
3.	L GAIN trimmer	Controls the gain of the left channel output.
4.	INPUT mini phone connector	Stereo/balanced mono audio input.
5.	ON Led	Illuminates when the machine is powered.
6.	12VDC feed connector	A DC connector that allows power to be supplied to the unit.



5.4 Getting to Know Your 105S Distributor

The Kramer 105S is a high performance 1x5 distribution amplifier for S-video (Y/C) signals. It accepts one input and distributes it to five identical outputs using standard 4 pin S-video connectors. Video bandwidth of 230MHz ensures that the 105S remains transparent even in the most critical applications. A 12VDC power supply is included for typical operation but the optional VA-50P can power up to six Kramer devices requiring 12VDC. The 105S is part of the Kramer **TOOLS** family of compact, high quality, and cost effective solutions for a variety of applications. Panel features of the 105S are described in Figure 4 and Table 4.

NOTE

For operation instructions refer to section 11.

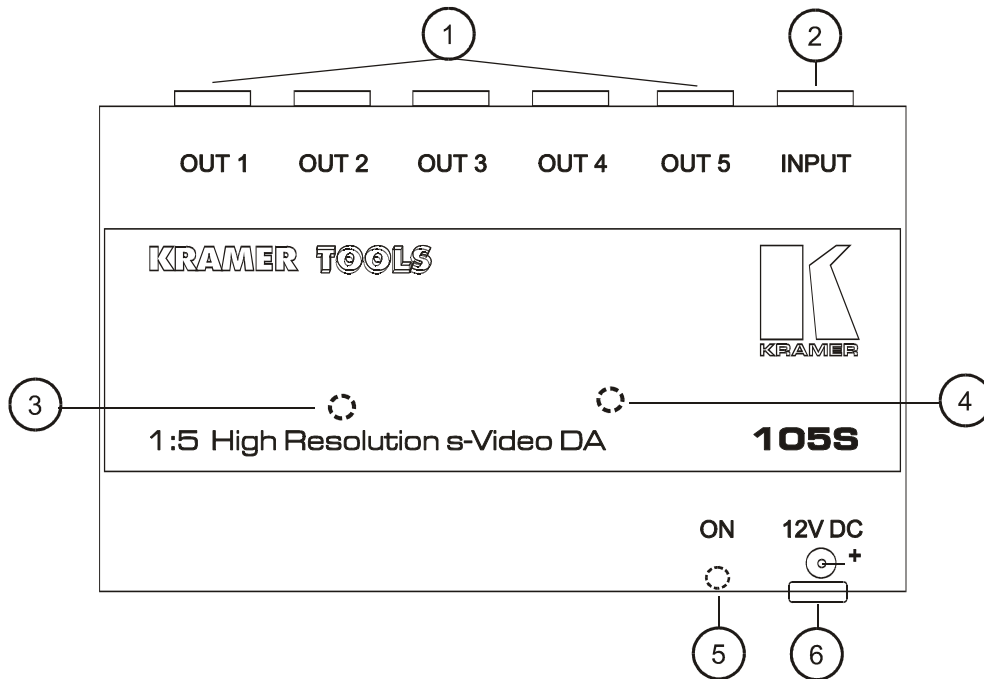

Figure 4: 105S Panel Features

Table 4: 105S Panel Features

No.	Feature	Function
1.	OUT 1- OUT 5 4P connectors	5 amplified and buffered s-video outputs.
2.	INPUT 4P connector	Video input.
3.	CHROMA trimmer	Adjusts (Chroma) Level of the output.
4.	LUMA trimmer	Adjusts (Luma) Level of the output.
5.	ON Led	Illuminates when the machine is powered.
6.	12VDC feed connector	A DC connector that allows power to be supplied to the unit.



5.5 Getting to Know Your 105V Distributor

The Kramer **105V** is a high performance 1x5 distribution amplifier for composite video signals. It accepts a single input and distributes it to five identical outputs using RCA connectors. Video bandwidth of 280MHz ensures that the **105V** remains transparent even in the most critical applications. A 12VDC power supply is included for typical operation but the optional VA-50P can power up to six Kramer devices requiring 12VDC. The **105V** is part of the Kramer **TOOLS** family of compact, high quality, and cost effective solutions for a variety of applications.

Panel features of the **105V** are described in Figure 5 and Table 5.

NOTE

For operation instructions refer to section 11.

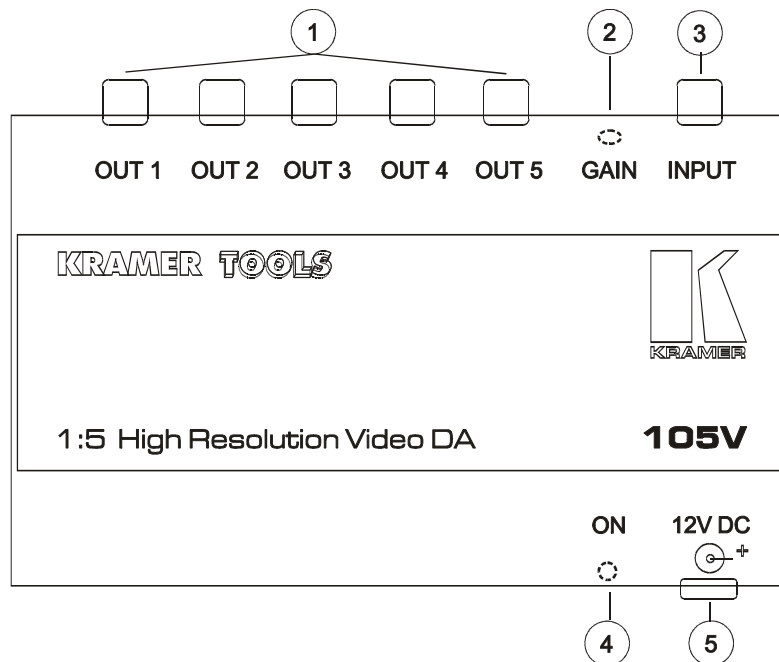

Figure 5: 105V Panel Features

Table 5: 105V Panel Features

No.	Feature	Function
1.	OUT 1- OUT 5 RCA connectors	5 amplified and buffered video outputs.
2.	GAIN trimmer	Controls the gain of the video outputs.
3.	INPUT RCA connector	Video input.
4.	ON Led	Illuminates when the machine is powered.
5.	12VDC feed connector	A DC connector that allows power to be supplied to the unit.



5.6 Getting to Know Your 105VB Distributor

The Kramer **105VB** is a high performance 1x5 distribution amplifier for composite video signals. It accepts one input and distributes it to five identical outputs using BNC connectors. Video bandwidth of 280MHz ensures that the **105VB** remains transparent even in the most critical applications. A 12VDC power supply is included for typical operation but the optional VA-50P can power up to six Kramer devices requiring 12VDC. The **105VB** is part of the Kramer **TOOLS** family of compact, high quality, and cost effective solutions for a variety of applications.

Panel features of the **105VB** are described in Figure 6 and Table 6.

NOTE

For operation instructions refer to section 11.

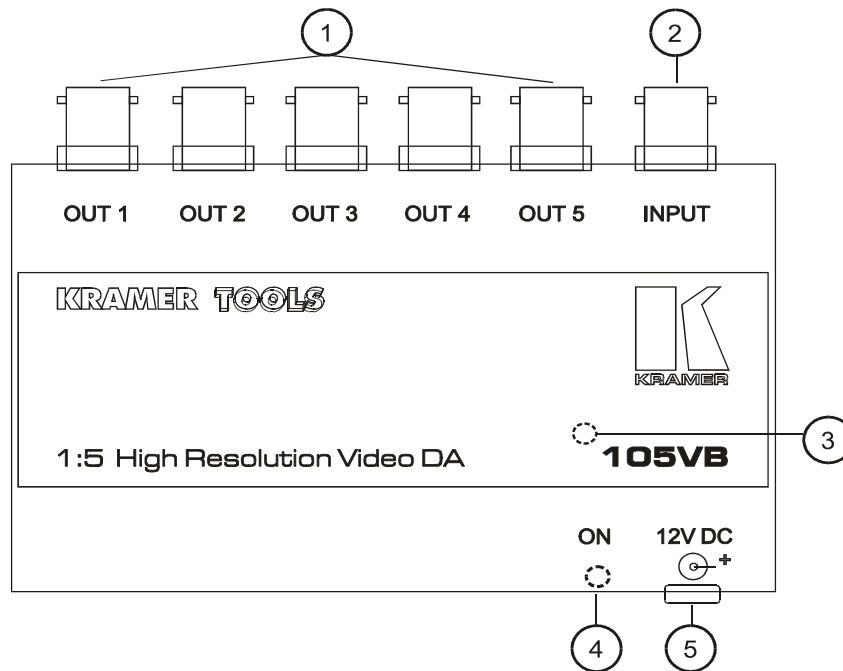

Figure 6: 105VB Panel Features

Table 6: 105VB Panel Features

No.	Feature	Function
1.	OUT 1- OUT 5 BNC connectors	5 amplified and buffered video outputs.
2.	INPUT BNC connector	Video input.
3.	GAIN trimmer	Adjusts the gain of the video outputs.
4.	ON Led	Illuminates when the machine is powered.
5.	12VDC feed connector	A DC connector that allows power to be supplied to the unit.



6 TYPICAL APPLICATIONS

IMPORTANT NOTE: The trimmers which are built-in the amplifiers were factory pre-adjusted to assure a 1:1 transparent operation. Readjusting the trimmers by the user will upset this transparency.

6.1 Typical Video Distribution

Figure 7 illustrates a typical setup of one of the distributors described in this manual. An incoming single input from source (VCR) is split into five identical outputs, connected to acceptors.

Perform the following steps (as necessary):

- 1) Connect the output of the video source to the video **INPUT** connector of the Distributor (105V in this case).
- 2) Connect the **OUTPUTS** of the 105V to the inputs of up to five video acceptors.
- 3) Operate the source, acceptors and the 105V.
- 4) Use the **GAIN** trimmer to control the gain of the video outputs if necessary (see section 11.2 for more details).

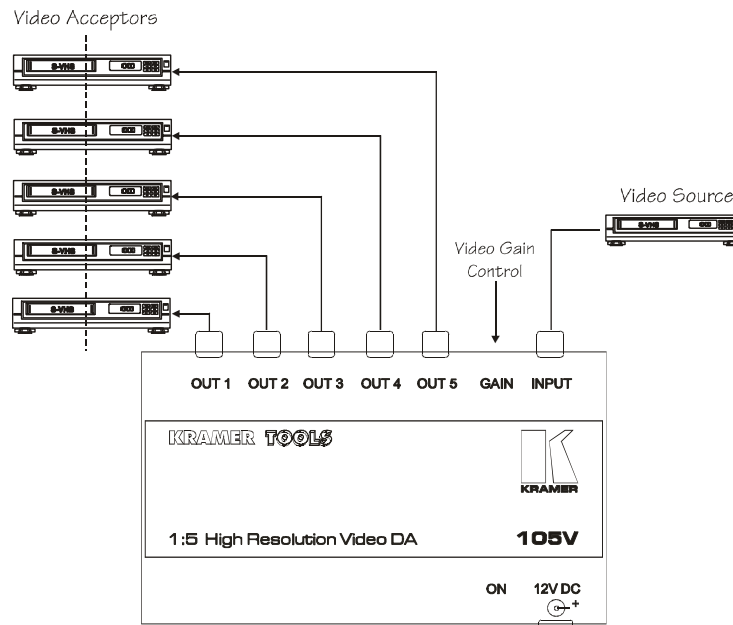

Figure 7: Typical Video Distribution

6.2 Increasing the Number of Outputs

The audio/video distributors described in this manual can be linked to increase the number of outputs by setting up a cascaded configuration. The example shown in Figure 8 describes a typical configuration of cascaded audio distributors (1:9 configuration in this case). Note that it is not recommended to cascade more than two machines. Perform the following steps:

- 1) Connect an audio source to the **INPUT** connector of the first 105A.
- 2) Connect up to four audio acceptors to the **OUTPUT** connectors of the first 105A.
- 3) Connect an audio cable from the **OUTPUT** connector of the first 105A to the **INPUT** connector of the cascaded 105A.
- 4) Connect up to five audio acceptors to the **OUTPUT** connectors of the cascaded 105A.
- 5) Operate the distributors, source and acceptors.
- 6) Use the **R, L GAIN** trimmers to control the left/right audio levels.

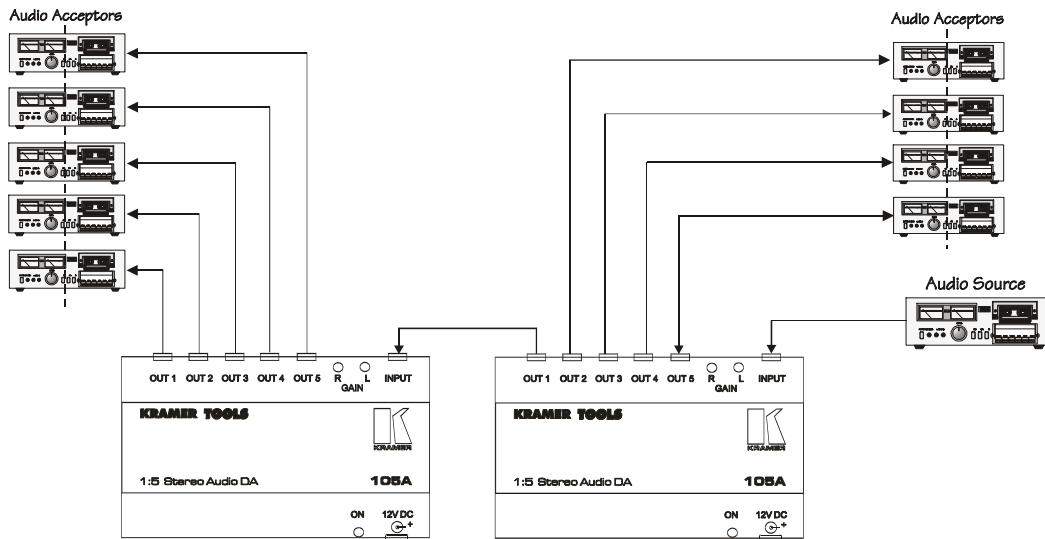

Figure 8: Cascading the Amplifiers

6.3 Increasing the Number of Inputs

When it is necessary to handle more than one input, a video switcher such as the 4x1VB or a bigger one such as the 801x1 can be used to select the required input to be switched to the outputs. The 4x1VB for example, can be serially connected between the video sources and the distribution amplifier for video switching. It is designed for composite video signals using BNC connectors, accepts up to four inputs and allows the user to select any input to be routed to one output using buttons located on the side panel. Figure 9 describes a typical switching configuration, where one of four video inputs is selected by a 4x1VB switcher and then outputted to a 105VB input. To extend the number of switcher outputs, up to five acceptors can be connected to the 105VB for multi video distribution of the selected input.

Perform the following steps:

- 1) Connect up to four video sources to the IN1-IN4 BNC connectors of the 4x1VB.
- 2) Connect a cable from the OUTPUT connector of the 4x1VB to the INPUT connector of the 105VB.
- 3) Connect up to five video acceptors to the OUT1-OUT5 connectors of the 105VB.
- 4) Use the INPUT SELECTOR switches of the 4x1VB to select the desired input to be switched.
- 5) Operate the 4x1VB, 105VB, sources and acceptors.
- 6) DO NOT USE the GAIN trimmer of the 105VB to control the level of the output signal, unless it is absolutely necessary! Please see the note at the beginning of this chapter.

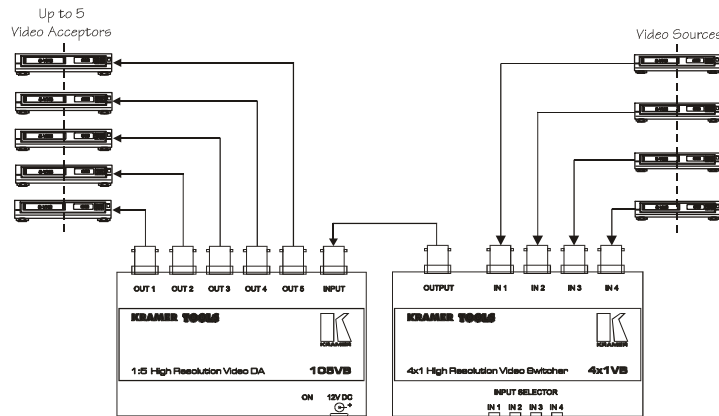

Figure 9: Increasing the Number of Inputs



6.4 Combined Audio and Video Distribution

When a combined audio and video distribution is required, a combination of independent audio and video sources together with an audio/video distributor should be set up. Figure 10 describes a typical configuration using the 103AV video distributor together with audio and video sources. The 103AV receives audio and video signals at its **INPUT** connectors. The 103AV splits its incoming audio and video inputs to three audio acceptors and three video acceptors.

Perform the following steps:

- 1) Connect a video source and an audio source to the **VIDEO** and **AUDIO INPUT** connectors of the 103AV.
- 2) Connect up to three audio acceptors to the **AUDIO OUTPUT** connectors of the 103AV.
- 3) Connect up to three video acceptors to the **VIDEO OUTPUT** connectors of the 103AV.
- 4) Operate the 103AV, video/audio sources and video/audio acceptors.
- 5) Only if absolutely necessary, you may use the **GAIN**, **L**, **R** trimmers of the 103AV to adjust the video and audio outputs. (See remark above).

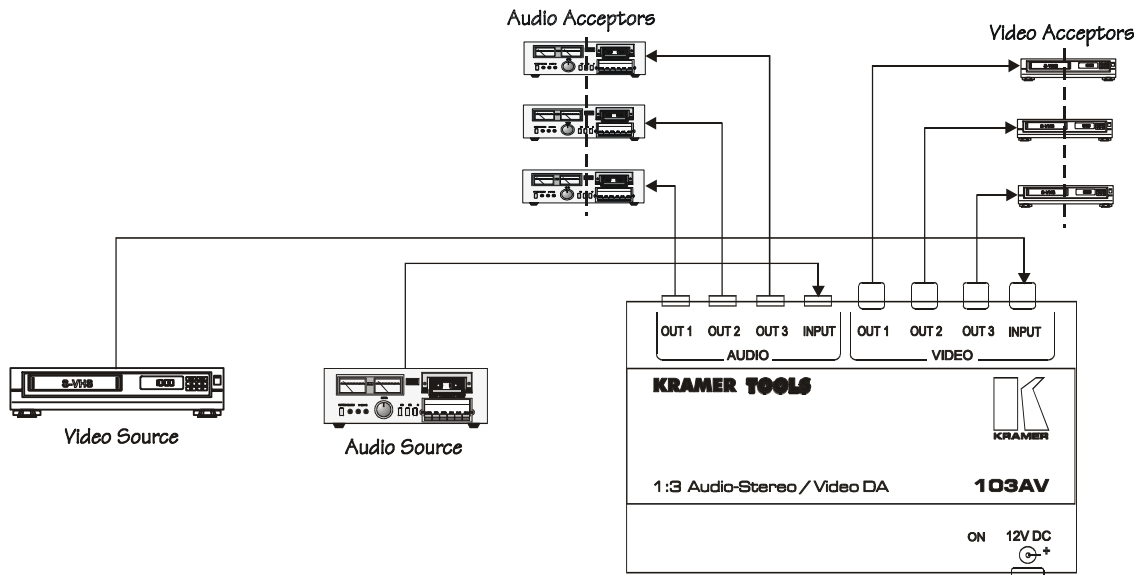

Figure 10: Combined Audio and Video Distribution

6.5 Line Amplification

Connecting cables do not behave as ideal transmission lines because of flaws in cable design and production. Sometimes the impedance of the cable is simply not as stated on the cable. Sometimes, due to imperfection in cable design, stray (parasite) capacitance and inductance appear along the cable and they have an adverse effect on signal quality. Line amplifiers overcome the following shortcomings of long cable installations:

- Loss of overall signal level.
- Loss of high frequency signals due to stray capacitance and inductance.
- Mismatch of cable impedance.

Line amplifiers should be installed as close as possible to the video source to achieve the best signal to noise ratio. The 104L Video Line Amplifier for example, is an excellent option to solve problems caused by using long cables. It can be serially connected between the video source and the distribution amplifier for video processing and in order to prevent video signal losses over long cables. The 103YC, VM-9S and the VM-9YC are other available options that can be used for the same purpose.

Figure 11 (A) describes a typical line amplification, using the 104L. The 104L, which is located as close as possible to the video source, receives a video signal from the source and splits the incoming signal to its four outputs. One of the outputs is connected to the 105VB distributors' input, while up to three local



acceptors can be connected to the other available outputs. The 105VB splits the incoming signal to five remote (long distance) acceptors. The LEVEL and EQ. controls of the 104L may be used to control the output remote display.

Perform the following steps:

- 1) Connect a video source to the **INPUT** connector of the 104L (locate the 104L as close as possible to the source).
- 2) Connect up to three local acceptors to the **OUTPUT** connectors of the 104L.
- 3) Connect a high quality BNC cable from one of the BNC **OUTPUTS** of the 104L to the **INPUT** connector of the 105VB.
- 4) Connect up to five acceptors to the **OUTPUT** connectors of the 105VB.
- 5) Operate the 104L, 105VB, video source and acceptors.
- 6) Use the front panel controls of the 104L to control the output display.

If only one of the distributors' outputs requires line amplification, while all the others are nearly located, connect the line amplifiers' input to the distributors' "long line desired" output as described in Figure 10 (B).

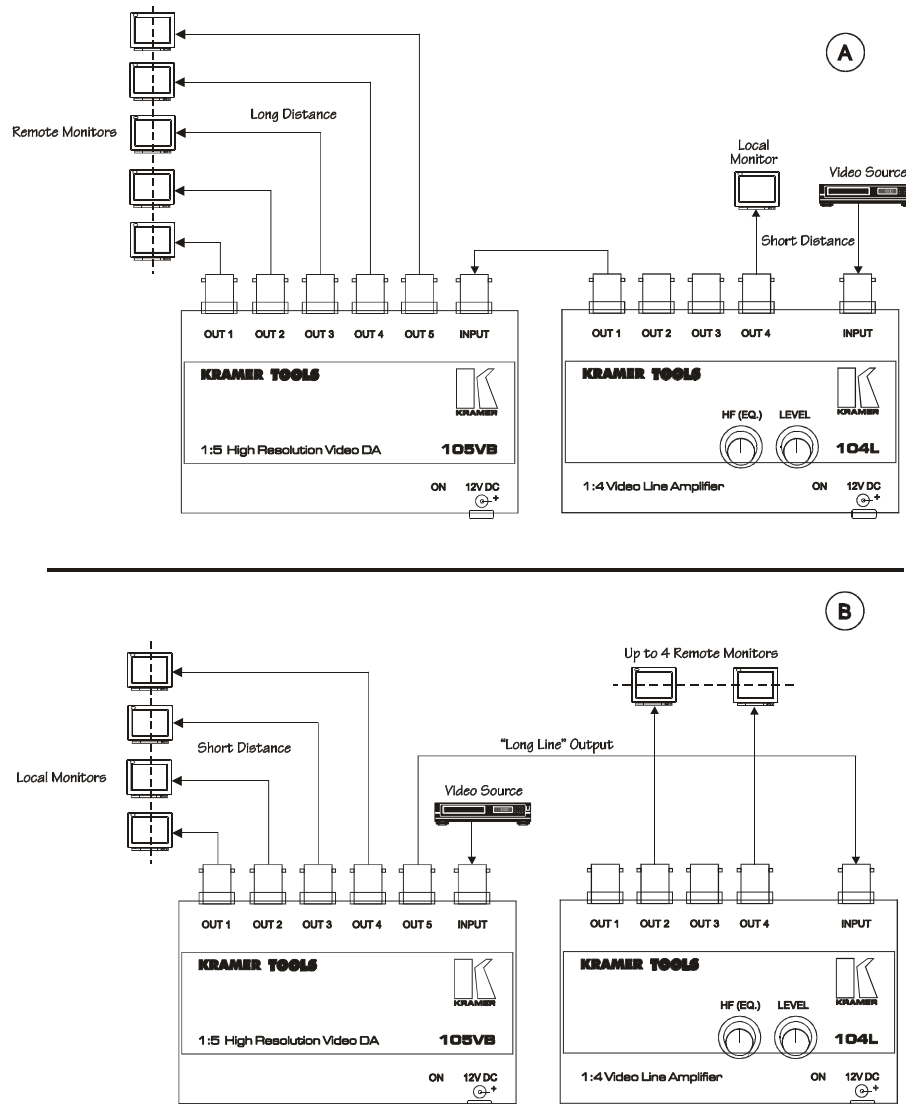

Figure 11: Typical Line Amplification



6.6 Image Enhancement

If sharpness, brightness, contrast or color is wrong, or/and video control/correction is required, a video processor should be installed between the video source and the distribution amplifier, as close as possible to the video source/s. The SP-11 video processor can be used for the above mentioned purposes. It provides camera control and luminance/white balance correction and is also capable of performing composite to Y/C conversion and bi-directional transcoding. The machine allows full control over the video signal: video gain down to full fade, log or linear definition control, log or linear contrast control, color saturation control, black level control, red, green and blue controls and a screen splitter control for "before-after" comparison. The Input switch control is "audio-follow-video". Figure 12 describes a typical image enhancement: A Super Video source is connected to the YC input of a Video Processor (SP-11 in this case) for image enhancement. The YC output of the SP-11 is outputted to a 105S Super Video Distributor for further distribution to Super Video acceptors. Up to four different sources may be connected to the SP-11 and each input can be selected by its input selector to be switched to the appropriate output.

Perform the following steps:

- 1) Connect the output of the Super Video source to the **YC INPUT** connector of the SP-11. Locate the processor as close as possible to the source.
- 2) Connect the **YC OUTPUT** connector of the SP-11 to the **YC INPUT** connector of the 105S.
- 3) Connect up to five Super Video acceptors to the **OUTPUT** connectors of the 105S.
- 4) Use the controls of the SP-11 to correct and adjust the image.

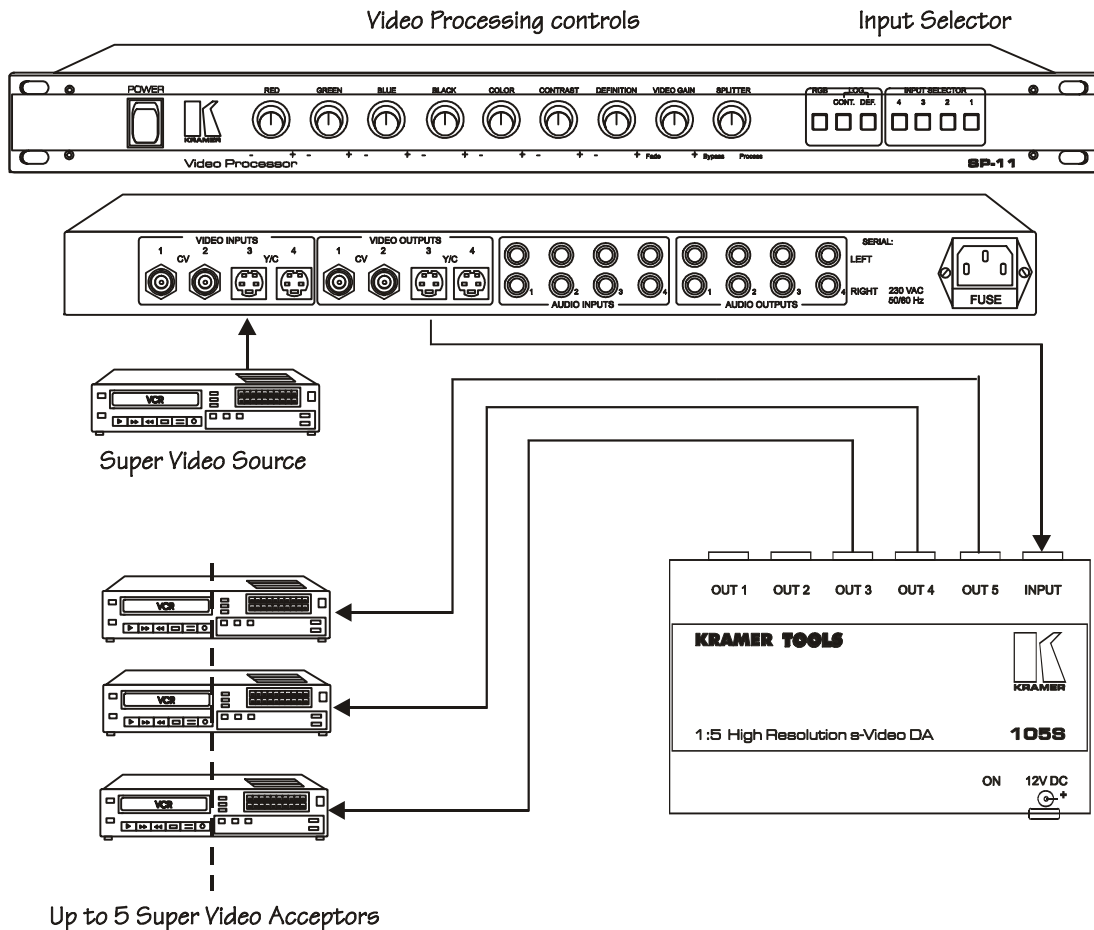

Figure 12: Image Enhancement



7 INSTALLATION

7.1 Rack Mounting

The Kramer **TOOLS** Distributors may be rack mounted in a standard 19" (1U) EIA rack assembly, using a special **TOOLS** Adapter (1U or 3U) and two mounting brackets (see section 4.1). They can be also table mounted using the mounting brackets provided. These devices do not require any specific spacing above or below the unit for ventilation. To mount any of the machines, follow the installation instructions enclosed with the machine.

8 CONNECTING TO VIDEO DEVICES

Video sources and output devices (such as monitors, projectors or recorders) may be connected to the **TOOLS** through the BNC type connectors (105VB), through the RCA type connectors (103AV and 105V) or through the 4P connectors (105S) located on the back of the unit. If you use separate Y and C cables for the distribution of s-Video, the cables must be at equal lengths. The signals supported by the various models are composite and S-video signals.

9 CONNECTING TO AUDIO DEVICES

Audio sources and output devices (such as amplifiers or recorders) may be connected to the **TOOLS** through the 3.5mm mini phone type connectors (103AV, 105A) or through the 6.5mm phone type connectors (104M) located at the back of the machine. The signals supported by the various models are Stereo-Audio, Balanced Mono and Mono Microphone.

10 USING THE MACHINES

10.1 Powering on the Machine

NOTES

- 1) The machine should only be powered on after all connections are completed and all source devices have been powered on. Do not attempt to connect or disconnect any video or audio signals to the machine while it is powered on.
 - 2) The socket-outlet should be near the equipment and should be easily accessible. To fully disconnect equipment, remove the power supply adapter from the mains socket.
- 1) Connect the machine's DC socket to the power supply (provided with the machine). Observe proper polarity! Observe that the LED on the panel is illuminated.
 - 2) Operate the source and the acceptors.

10.2 Gain Control (103AV, 105V, 105VB only)

The Gain Control function enables the operator to adjust the picture intensity level and compensate for losses caused by too long or non-standard cables. The Gain control trimmers should be used only if you are absolutely sure that the problem arises from the cables or connectors. Unnecessary use of those trimmers will upset the factory adjustments and the 1:1 signal transparency will be lost.

10.3 Luma Control (105S only)

The Luma Level control should be treated similarly to the Video Gain control described above. Unnecessary adjustments will upset the 1:1 signal transparency. Equalization problems that occur due to long or non-standard cables, resulting in fine detail loss may be compensated by using the VM-9YC Y Equalization Control function.



10.4 Chroma Control (105S only)

The Chroma Level control should be treated similarly to the Video Gain control described above. Unnecessary adjustments will upset the 1:1 signal transparency. Equalization problems that occur due to long or non-standard cables, resulting in color distortion problems may be compensated by using the VM-9YC Chroma Equalization Control functions.

10.5 Audio Level Control (103AV, 104M, 105A only)

To adjust the audio level, simply adjust the **L**, **R** audio level trimmers (103AV and 105A models), or the **GAIN** trimmer (104M model) until a satisfactory audio level is achieved.

11 TAKING CARE OF YOUR MACHINE

Do not locate your machine in an environment where it is susceptible to dust or moisture. Both of these may damage the electronics, and cause erratic operation or failure. Do not locate your machine where temperature and humidity may be excessive. Doing so may also damage the electronics, and cause erratic operation or failure of your machine. Do not clean your machine with abrasives or strong cleaners. Doing so may remove or damage the finish, or may allow moisture to build up. Take care not to allow dust or particles to build up inside unused or open connectors.

12 TROUBLESHOOTING

NOTES

1. Please note that if the output signal is disturbed or interrupted by very strong external electromagnetic interference, it should return and stabilize when such interference ends. If not, disconnect power from the machine and reconnect again to reset the machine.
2. If the recommended actions still do not result in satisfactory operation, please consult your KRAMER Dealer.

12.1 Power and Indicators

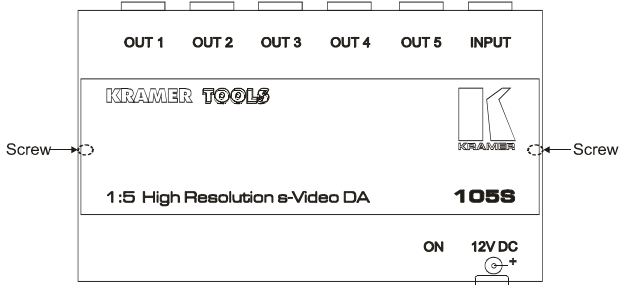
Problem	Remedy
No power	<ol style="list-style-type: none"> 1. Confirm that power connections are secured at the machine and at the receptacle. Make sure the receptacle is active, outputting the proper voltage. 2. If there is still no power use a Philips screwdriver to remove screws on both sides of the machine and release the panel.  <ol style="list-style-type: none"> 3. Locate fuse inside your machine (see Figure 13). Confirm that the fuse is good by looking for the wire connected between the ends of the fuse. If this wire is broken, replace fuse with another, with the same rating. 4. Install cover by tightening the Philips screws.

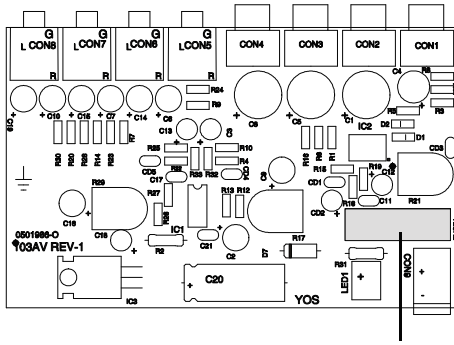

103AV Fuse

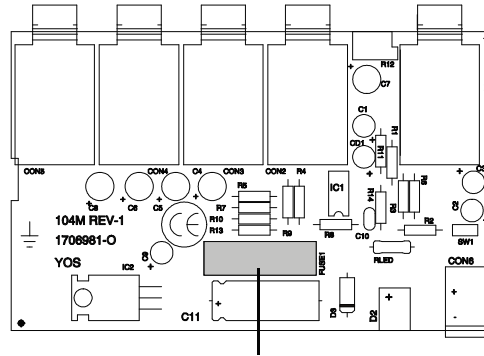

104M Fuse

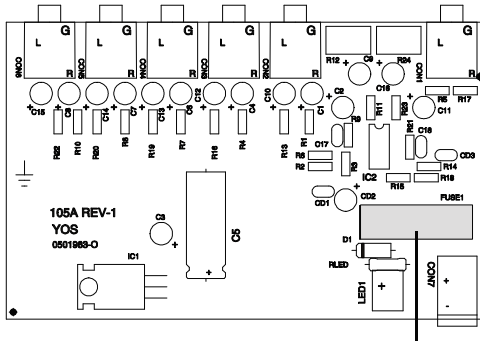

105A Fuse

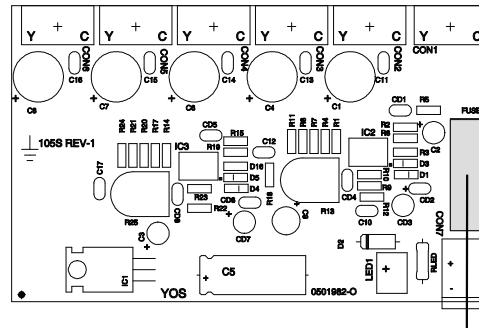

105S Fuse

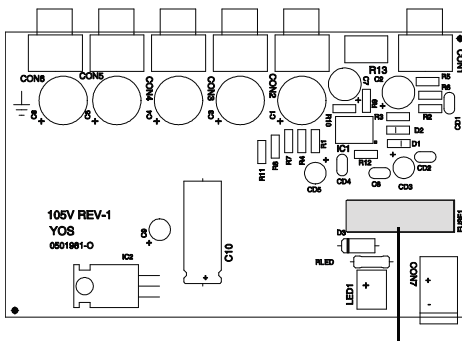

105V Fuse

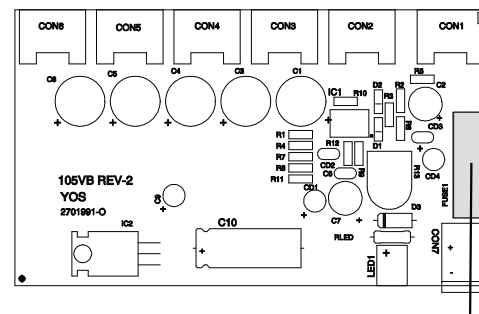

105VB Fuse

Figure 13: Fuse Locations



12.2 Video Signal

Problem	Remedy
No video at the output device, regardless of input selected.	<ol style="list-style-type: none"> 1. Confirm that your source and output devices are powered on and connected properly. The input of your machine should be of an identical signal format at the output of your source. Signals at the output of your machine should be of an identical signal format as at the input of your display. 2. Confirm that any other device in the signal path have the proper input and/or output selected. 3. Use the Video Tester to test the video path leading to/from your machine (see section 4.1" Video Tester")
Video level is too high or too dim.	<ol style="list-style-type: none"> 1. Verify that the lines are well matched through 75ohm impedances; otherwise it results in a video level that is too high or too dim. 2. Confirm that the connecting cables are of high quality and properly inserted. 3. Check level controls located on your source input device or output display.
Noise bars are "rolling" up or down in the output image or: Low Frequency Hum in the output signal	<p>Hum bars (ground loop) are caused by a difference in the ground potential of any two or more devices connected to your signal path.</p> <p style="text-align: center;">WARNING! <i>Do not disconnect the ground from any piece of video equipment in your signal path!</i></p> <p>Check the following to remove hum bars:</p> <ol style="list-style-type: none"> 1. Confirm that all interconnected equipment is connected to the same phase of power, if possible. 2. Remove equipment connected to that phase that may introduce noise, such as motors, generators, etc. 3. Disconnect all interconnect cables and reconnect them one at a time until ground loop reappears. Disconnect the affected cable and replace, or insert an isolation transformer in the signal path.

12.3 Audio Signal

Problem	Remedy
No audio at the output device, regardless of input selected	<ol style="list-style-type: none"> 1. Confirm that your sources and output device are powered on and connected properly. Audio signals connected to the input of your machine should be properly wired to the output of your source. Audio signals connected to the output of your machine should be properly wired to the input of your machine or recorder. 2. Confirm that any other amplifiers in the signal path have the proper input and/or output selected. Pay special attention to input amplifiers that may be built into your acceptor.
Audio level is too low	<ol style="list-style-type: none"> 1. Confirm that the connecting cables are of high quality and properly built. Take special care in noting the wiring configuration of balanced to unbalanced cables. 2. Check level controls located on your source input device or output display or recorder.



LIMITED WARRANTY

Kramer Electronics (hereafter Kramer) warrants this product to be free from defects in material and workmanship under the following terms.

HOW LONG IS THE WARRANTY

Labor and parts are warranted for three years from the date of the first customer purchase.

WHO IS PROTECTED

Only the first purchase customer may enforce this warranty.

WHAT IS COVERED AND WHAT IS NOT COVERED

Except as below, this warranty covers all defects in material or workmanship in this product. The following are not covered by the warranty:

- 1) Any product which is not distributed by Kramer or which is not purchased from an authorized Kramer dealer. If you are uncertain as to whether a dealer is authorized, please contact Kramer at one of the agents listed in the web site www.kramerelectronics.com.
- 2) Any product, on which the serial number has been defaced, modified or removed.
- 3) Damage, deterioration or malfunction resulting from:
 - a) Accident, misuse, abuse, neglect, fire, water, lightning or other acts of nature.
 - b) Unauthorized product modification, or failure to follow instructions supplied with the product.
 - c) Repair or attempted repair by anyone not authorized by Kramer.
 - d) Any shipment of the product (claims must be presented to the carrier).
 - e) Removal or installation of the product.
 - f) Any other cause, which does not relate to a product defect.
 - g) Cartons, equipment enclosures, cables or accessories used in conjunction with the product.

WHAT WE WILL PAY FOR AND WHAT WE WILL NOT PAY FOR

We will pay labor and material expenses for covered items. We will not pay for the following:

- 1) Removal or installations charges.
- 2) Costs of initial technical adjustments (set-up), including adjustment of user controls or programming. These costs are the responsibility of the Kramer dealer from whom the product was purchased.
- 3) Shipping charges.

HOW YOU CAN GET WARRANTY SERVICE

- 1) To obtain service on you product, you must take or ship it prepaid to any authorized Kramer service center.
- 2) Whenever warranty service is required, the original dated invoice (or a copy) must be presented as proof of warranty coverage, and should be included in any shipment of the product. Please also include in any mailing a contact name, company, address, and a description of the problem(s).
- 3) For the name of the nearest Kramer authorized service center, consult your authorized dealer.



LIMITATION OF IMPLIED WARRANTIES

All implied warranties, including warranties of merchantability and fitness for a particular purpose, are limited in duration to the length of this warranty.

EXCLUSION OF DAMAGES

Kramer's liability for any defective products is limited to the repair or replacement of the product at our option. Kramer shall not be liable for:

- 1) Damage to other property caused by defects in this product, damages based upon inconvenience, loss of use of the product, loss of time, commercial loss; or:
- 2) Any other damages, whether incidental, consequential or otherwise. Some countries may not allow limitations on how long an implied warranty lasts and/or do not allow the exclusion or limitation of incidental or consequential damages, so the above limitations and exclusions may not apply to you.

This warranty gives you specific legal rights, and you may also have other rights, which vary from place to place.

NOTE: All products returned to Kramer for service must have prior approval. This may be obtained from your dealer.

NOTICE

This equipment has been tested to determine compliance with the requirements of:

- EN-50081:** "Electromagnetic compatibility (EMC);
generic emission standard.
Part 1: Residential, commercial and light industry"
- EN-50082:** "Electromagnetic compatibility (EMC) generic immunity standard. Part 1:
Residential, commercial and light industry environment".
- CFR-47** FCC Rules and Regulations:
Part 15- "Radio frequency devices:
Subpart B- Unintentional radiators

CAUTION

- Any user who makes changes or modifications to the unit without the express approval of the manufacturer will void user authority to operate the equipment.
- Use the DC power supply (provided) to supply power to the machine and controllers.
- Please use recommended interconnect cables to connect the machine to controllers and other components.



For the latest information on our products and a list of Kramer distributors, visit our Web site: www.kramerelectronics.com.

**Updates to this user manual may be found at
<http://www.kramerelectronics.com/manuals.html>.**

We welcome your questions, comments and feedback.



Kramer Electronics, Ltd.

Web site: www.kramerelectronics.com

E-mail: info@kramerel.com

P/N: 2900-009001 REV 2