



**BRETFORD**

# LAPTG15ESA

## ASSEMBLED NOTEBOOK STORAGE CART

### Assembly Instructions

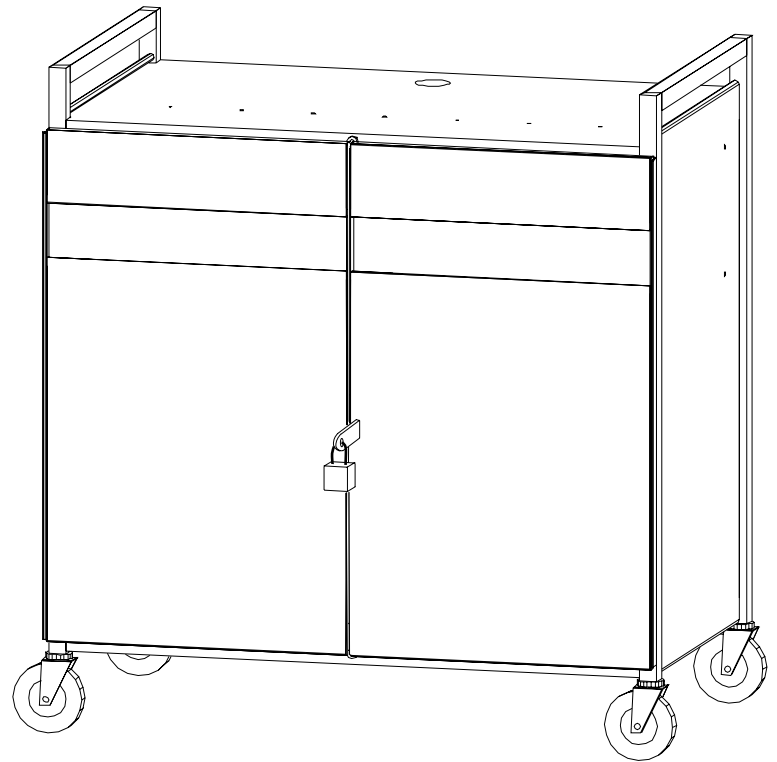

**Minimal assembly time of 15 minutes required**

**CAUTION:** The power tap included with model LAPTG15E-GM is designed for a standard 15 amp service and is intended to be used for charging 15 laptop computers. Any other use may overload the circuit and cause the circuit breaker to trip. The circuit breaker is built into the on/off switch located on the right side of the power tap above the power cord exit. To reset the circuit breaker, simply turn the power tap off and then on, again.

**CAUTION: RISK OF ELECTRICAL SHOCK. DO NOT  
PLUG INTO ANOTHER RELOCATABLE POWER TAP.**

### PARTS LIST

<u>Qty</u>	<u>Part#</u>	<u>Description</u>
1		Cart Assembly
1	LAP15E-Unit	Electrical Unit

### HARDWARE LIST

<u>Qty</u>	<u>Part#</u>	<u>Description</u>
16	012-0333	Black Adhesive Clip
1	010-3583GM	Lock Bracket
	010-3583TZ	Lock Bracket
2	030-0291	#10-32 x 1/2" Slotted Phillip Head
1	031-3950	Cable ties 11" long
2	030-1066	Padlock (Revised)
4	030-0006	1/4-20 Wing Nut

### TOOLS REQUIRED

Phillips Screwdriver  
Straight Screwdriver

**NOTE:** The black adhesive clips are used for cable management and can be placed in any desired location.

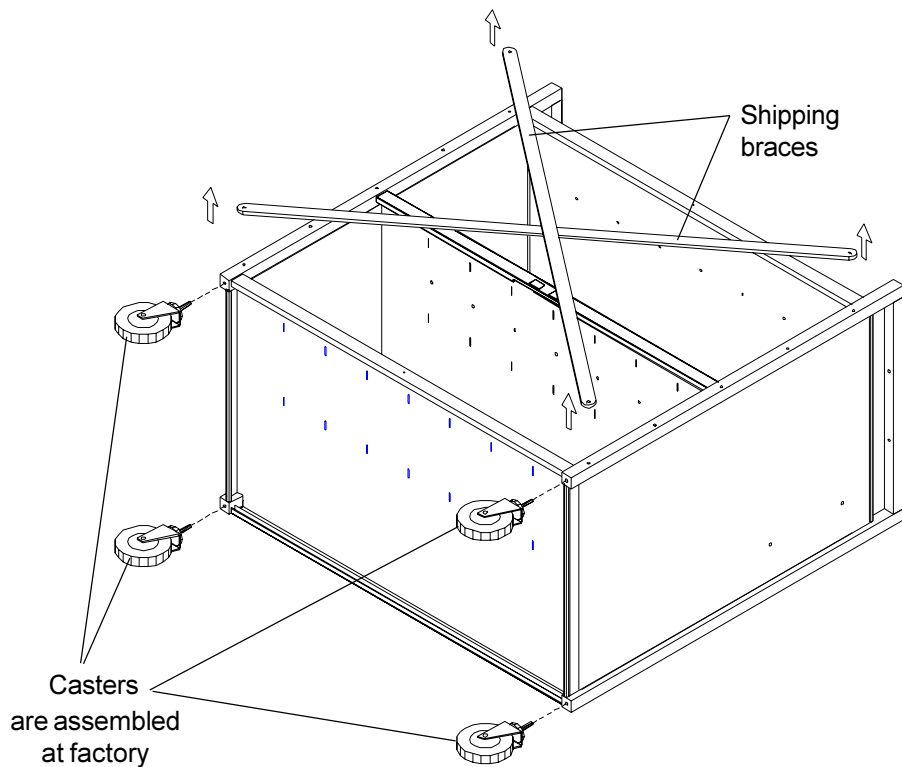

### STEP 1

Lay the cart assembly on its back. Remove braces (braces are used for shipping purpose only). Doors not shown (removed pictorially for clarity).

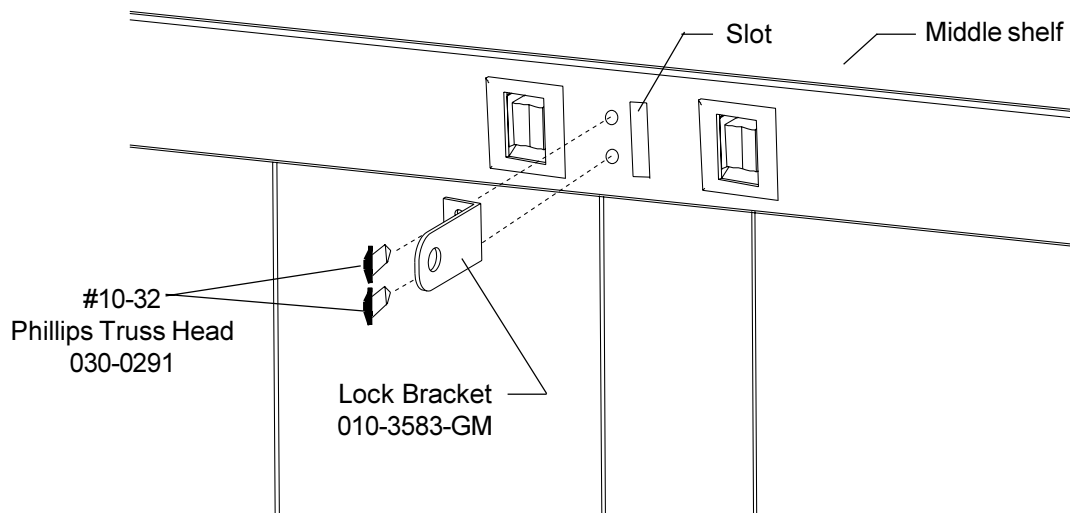

### STEP 2

Insert the short side of the lock bracket (010-3583) into the slot and secure it with two #10-32 Phillips Truss Head screws 030-0291.

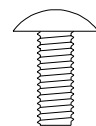

#10-32  
Phillips Truss Head  
030-0291

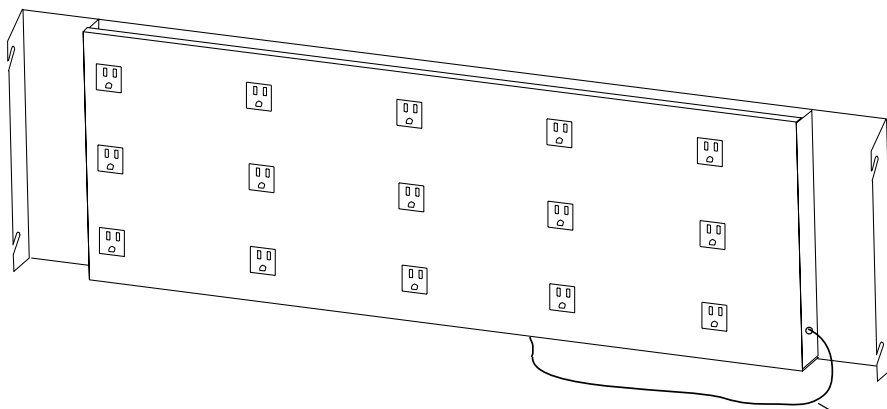

LAP15E-Unit

Electric Cord

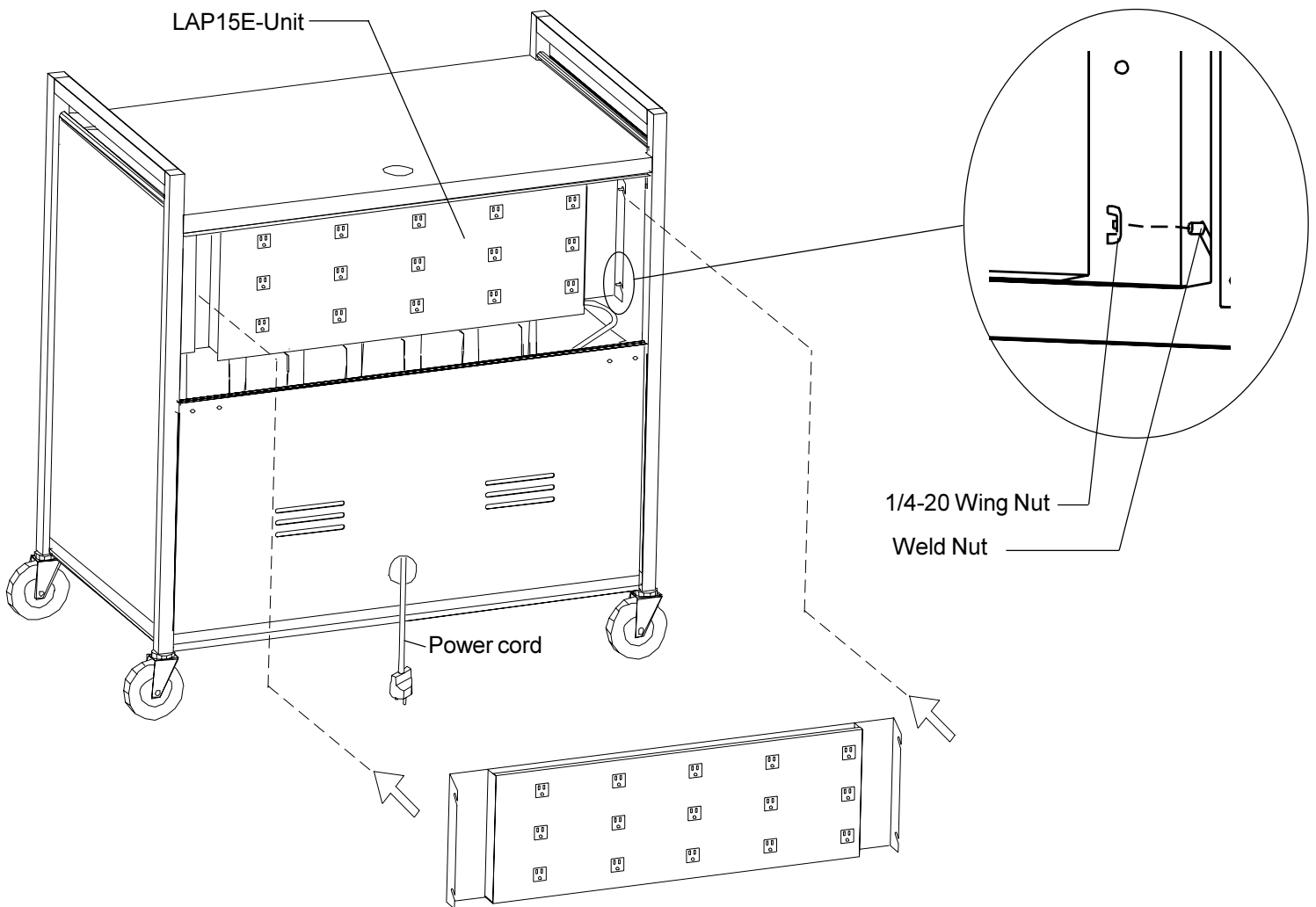

LAP15E-Unit

Power cord

1/4-20 Wing Nut

Weld Nut

### STEP 3

The Power Tap is to be located in the upper half of the cart. Power outlets must face the back of the cart. Move the Power Tap into the cart and slide it onto the weld nuts on both sides of upper half of your cart. Secure the Power Tap in place with four wing nuts. Attach the wing nuts onto the weld nuts as shown. **NOTE:** The E-unit **MUST ONLY** be installed using the hardware provided. Pull the power cord through the large grommated hole in the lower back panel as shown.

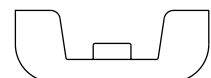

1/4-20 Wing Nut  
030-0006

## WARRANTIES

BMI engineers and manufactures its products to provide dependable operation. Therefore, BMI warrants that all products it manufactures are, at date of shipment free, from defects in material or workmanship. Therefore, any product which under normal use fails to function within the time periods specified below and found defective in material or workmanship by the Company's inspection will be repaired or replaced without charge to the buyer or, at the election of BMI, a credit will be allowed up to the invoice purchase price of the product. This warranty is inapplicable where, in the judgment of BMI, the defect is attributable to normal wear, misapplication, abnormal use, misuse, modification or damage after shipment, including damage caused by the buyer's failure to properly maintain, or other similar cause.

This warranty is expressly in lieu of any other express or implied warranties, including any other implied warranty of merchantability or fitness for ordinary or particular purpose. There are no other warranties which extend beyond the description on the face hereof.

Bretford Furniture

Ten (10) years from date of shipment.

Electrical Assemblies/Components

One (1) year from date of shipment.

## **Resettable Combination Padlock**

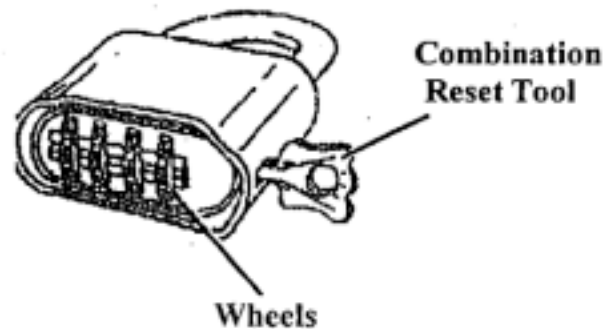

### Open Lock The First Time

- 1) Set the combination to 0-0-0-0
- 2) Depress shackle and pull open.

### To Set You Own Combination

**\*\*REMEMBER:** Combination can only be set when lock is open.

- 1) Insert "reset" tool (included in package) in hole on side of lock.
- 2) Push key in and turn key 90 degrees in either direction.  
(Key automatically stays in this position).  
Failure to exert force while pushing key in will result in a failed attempt to set or reset combination.
- 3) Set wheels to desired combination.
- 4) Turn and remove reset tool. Lock is now set to new combination.

**\*\*BE SURE TO RECORD YOUR COMBINATION.**

- 5) To lock scramble the wheels and close the shackle.
- 6) To reopen dial your combination and depress shackle.

**Bretford**  
11000 Seymour Avenue  
Franklin Park, Illinois 60131  
Tel: 847.678.2545  
800.521.9614  
Fax: 847.678.0852  
800.343.1779

**Bretford Mfg. Ltd.**  
2 Etongate  
110 Winsor Rd, Slough  
Berkshire, UK SL1 2JA  
Tel: 01753 539955  
Fax: 01753 539478

[www.bretford.com](http://www.bretford.com)

Part# 031-6639  
Rev. 08.29.05 CH