

BRETFORD BASICS™

OVERHEAD PROJECTOR CART

AOH2741-P4 & AOH2741-E4

Select the overhead projector cart to organize your next presentation. Adjustable projector well allows you to place the projector at the correct height. Constructed of steel and finished in black powder paint, this mobile cart can be easily used in a variety of rooms.



FEATURES

- Ideal for any presentation by quickly adapting to stand up or sit down applications.
- Sturdy worksurface supports your computer and an overhead projector.
- Features worksurface which height adjusts from 27" to 41" in 2" increments for seated or standing applications.
- Projector well is adjustable from 5" to 11" below the worksurface in 1/2" increments.
- Easy adjustability by simply resetting the leg screws.
- Convenient storage space below projector well holds papers and overheads for easy access.
- Smooth rolling 4" hard rubber casters, two lock.
- Durable all-steel construction finished in black powder paint.
- AOH2741-E4 includes a UL and C-UL listed 2-outlet electrical assembly with 20-foot extension cord and winder.

DIMENSIONS

Overall: 37" w x 22-1/2" d x 27-41" h

Projector Well: 17-1/2" w x 20-1/2" d

Shelf/Drawer: 17-11/16" w x 18-3/8" d x 4" h

COLOR & FINISH

Black (BK) powder paint

STANDARD EQUIPMENT

37" w x 22-1/2" d table with projector well, top section

H-frame, bottom section

1" round plastic caster inserts (4)

4" diameter casters (4), 2 with locking brakes

Plastic bag with all necessary hardware for assembly

2-Outlet Electrical Unit (1), AOH2741-E4 only

WEIGHT AND FREIGHT CLASS

AOH2741-P4: 64 lbs., Freight class 85 UPS

AOH2741-E4: 67 lbs., Freight class 85 UPS

Ships ready to assemble in one (1) carton pack

ACCESSORIES

E-Unit Electrical assembly with 2 grounded outlets, 20 ft. grounded extension cord. UL listed when mounted on table.

ES-Unit Electrical assembly with 3 grounded outlets, 20 ft. grounded extension cord. UL listed when mounted on table.

044-0025 5" caster pack with 2 locking brakes (can substitute for 4" casters)

CARTON DIMENSIONS & UPC CODE

38-1/2" w x 24-1/2" d x 20" h

AOH2741-P4: 96633 10655

AOH2741-E4: 96633 10651

SUGGESTED SPECIFICATIONS

AOH2741 Adjustable Overhead Projector Table has one (1) 20-gauge steel shelf, 37" w x 22-1/2" d. Shelf is press formed so that a 1/8" lip borders the top surface on all four sides. Surface is divided into two parts: a 17-1/2" writing surface and a 17-1/2" adjustable projector shelf. Four (4) 14-gauge steel legs, 20-1/4" in length, are welded to the shelf at each corner. Each leg has four (4) 1/4" diameter holds down the center so it accepts a 1/4" 20 machine screw. The holes are spaced 2" apart to permit table adjustments of 27", 29", 31", 33", 35", 37", 39" and 41" in height. Adjustable projector shelf can be lowered in 1/2" increments from 5", 5-1/2", 6", 6-1/2", 7", 7-1/2", 8", 8-1/2", 9", 9-1/2", 10", 10-1/2" and 11" positions that will accommodate different sizes of overhead projector models. Projector shelf is fastened to the top shelf on three (3) sides: at the back, outside of shelf on right, and

to the writing surface on the left side. Table shall have one (1) 20-gauge steel 36" w x 18" h modesty panel that is attached between the rear legs. Adjustable projector table has one (1) 14-gauge steel, welded "H" frame assembly. Four (4) 14-gauge steel legs, 19" in length, are welded to the "H" frame. Each leg has one (1) 1/4" diameter hole spaced 2" from the top and in the center so it allows eight (8) height adjustments (as noted above). Arc welded caster socket with a hard plastic caster insert is secured to the legs. Casters are mar-resistant Black hard rubber and are 4" in diameter. Each caster assembly has ball bearing swivel capabilities and steel construction. Two (2) have locking brakes. Optional electrical assembly is completely enclosed with two (2) grounded outlets, 20' 3-wire cord and two (2) 3/16" diameter machine screws with wing nuts for attaching unit to the table. Optional electrical assembly is C-UL and UL listed when attached. Table ships ready to assemble (K.D.) in one (1) carton pack, 24-1/5" w x 38-1/2" h x 20" d.

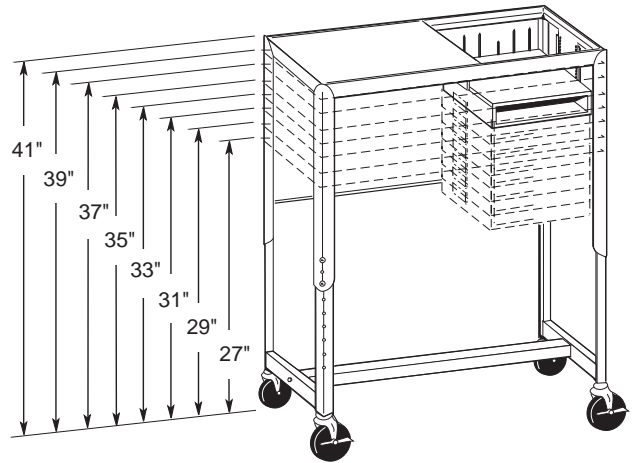

11000 SEYMOUR AVENUE
FRANKLIN PARK, ILLINOIS 60131 USA
TOLL FREE PHONE 800-521-9614
PHONE 847-678-2545
TOLL FREE FAX 800-343-1779
FAX 847-678-0852
WWW.BRETTFORD.COM