



BBILS1

LEVEL 1 ILS CART

Assembly Instructions

PART LIST

Qty	Part#	Description
2	010-1891	Top and Middle Shelves
1	010-1892	Bottom Shelf
2	010-4508	Shelf Support Brackets
1	010-4515	Slide Out Shelf
2	022-1645	L/Front & R/Rear Legs
2	022-1646	R/Front & L/Rear Legs
1	030-1191	14" Full Extension Slide
2	015-0002	4" Casters w/o Lock
2	015-0003	4" Casters w/ Lock
OR		
2	015-0017	5" Casters w/o Lock
2	015-0018	5" Casters w/ Lock

HARDWARE LIST

Ref	Qty	Part#	Description
AA	24	030-0300	5/8" square Head Bolts
BB	24	030-0002	5/16-18 Serrated Nuts
CC	8	030-0304	1/4-20 x 5/8" Combo Screws
DD	4	030-0302	8-32 x 3/8" Combo Truss Screws
EE	4	030-1203	#8-32 Acorn Nuts
FF	4	02236	8-32 Flange Whiz Lock Nuts
	4	012-0333	Black Wire Clips
	1	010-1106	Hex Wrench

TOOLS REQUIRED

- Hex Wrench (Provided)
- Box Wrench
- Phillips Screwdriver
- Rubber Mallet

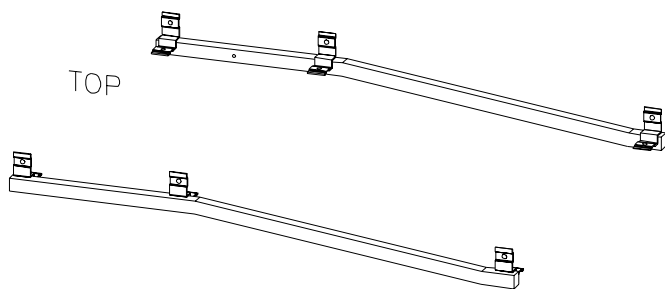

FIGURE 1

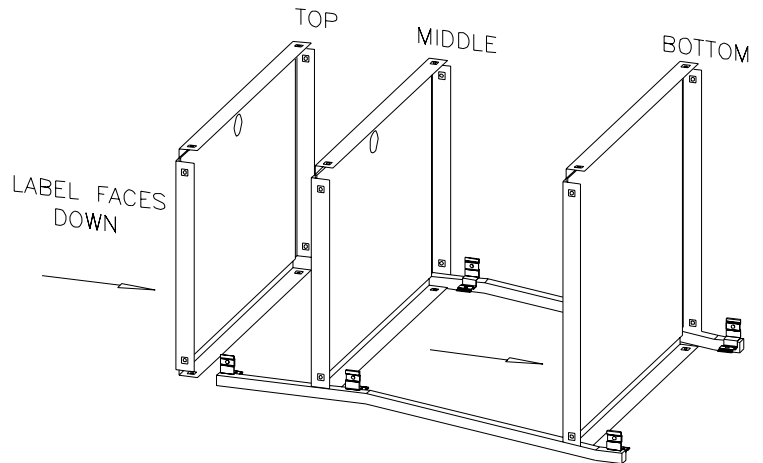
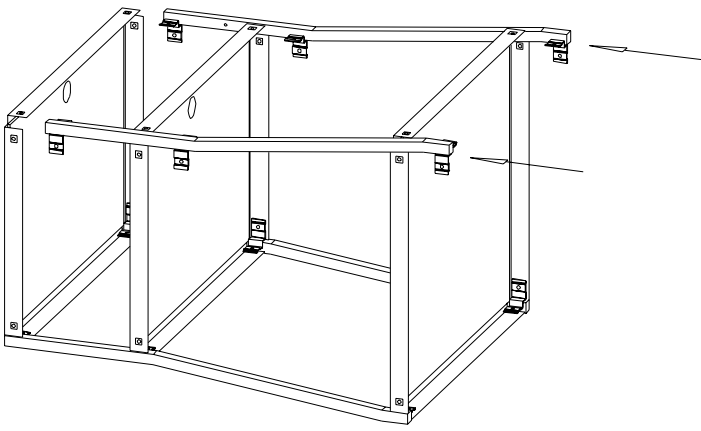

FIGURE 2

STEP 1

Lay the front legs on a carpeted surface with holes facing in and brackets facing up and in as shown in **Figure 1**. Each leg is stamped with either an "X" or an "O". When laying out the front legs you should have one "X" and one "O" leg. Slide each shelf onto the legs so that the brackets are inside the shelves as shown in **Figure 2**. **NOTE:** Make sure the grommet holes face upward.



STEP 2

Slide the 2 rear legs onto the shelves so that the brackets are inside the shelves.

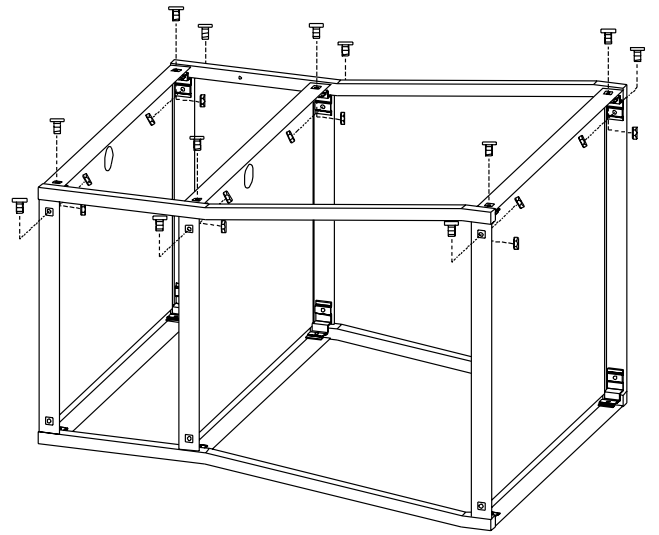

STEP 3

LOOSELY attach each shelf to the legs using bolts (AA) and nuts (BB) as shown.

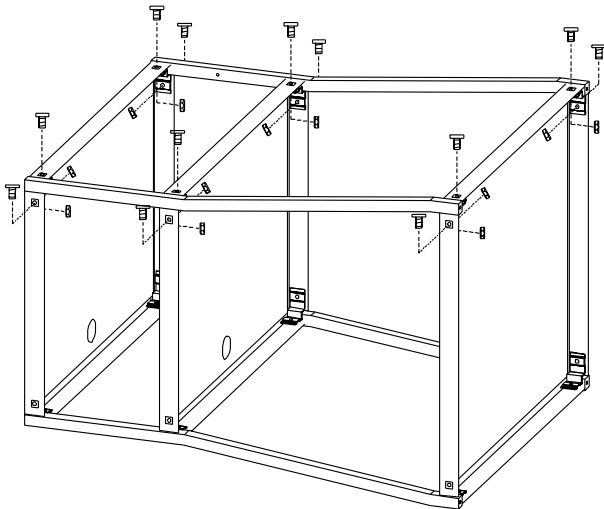
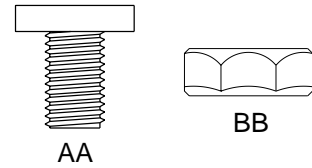

STEP 4

CAREFULLY turn unit over. Fasten each corner with bolts (AA) and nuts (BB). **TIGHTEN ALL HARDWARE.**

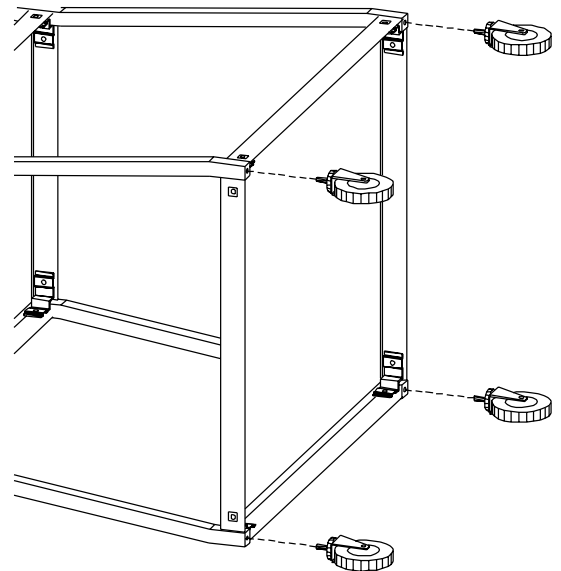

STEP 5

Insert each caster into the bottom of each leg. If casters do not insert easily, tap each caster into place. Make sure each caster is **SECURELY** in place and stand unit upright.

SHELF SUPPORT BRACKET

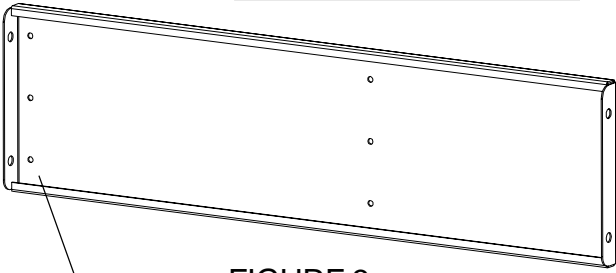

FIGURE 3

These holes need to face the edge you want the shelf to slide out on.

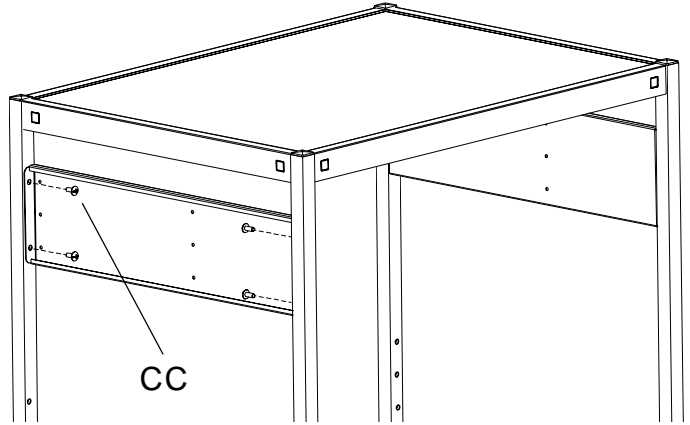
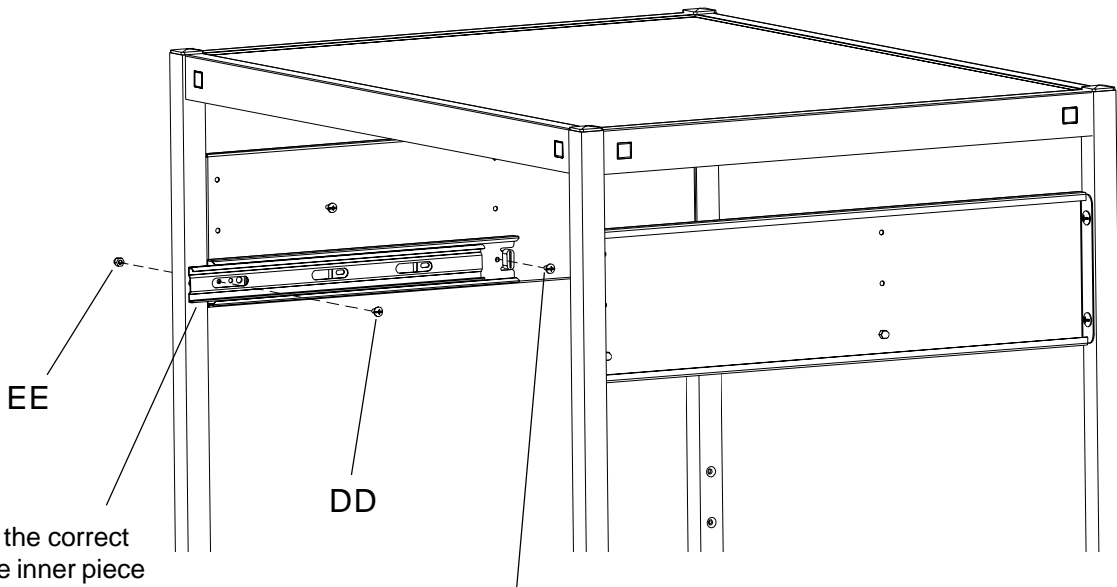

FIGURE 4



To access the correct holes, slide inner piece out slightly.

Attach rear screw & nut FIRST.

FIGURE 5

STEP 6

Determine which side you want your shelf to pull out from. Use **FIGURE 3** as reference. Attach the shelf support brackets to either set of holes (depending on your desired height) between the legs with screws (CC) as shown in **FIGURE 4**. Then separate each slide and attach the outer section to the inside of each shelf support bracket with screws (DD) and nuts (EE) as shown in **FIGURE 5**. **NOTE: Attach rear screw and nut first.**

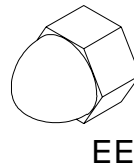
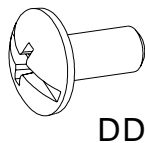
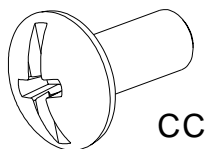

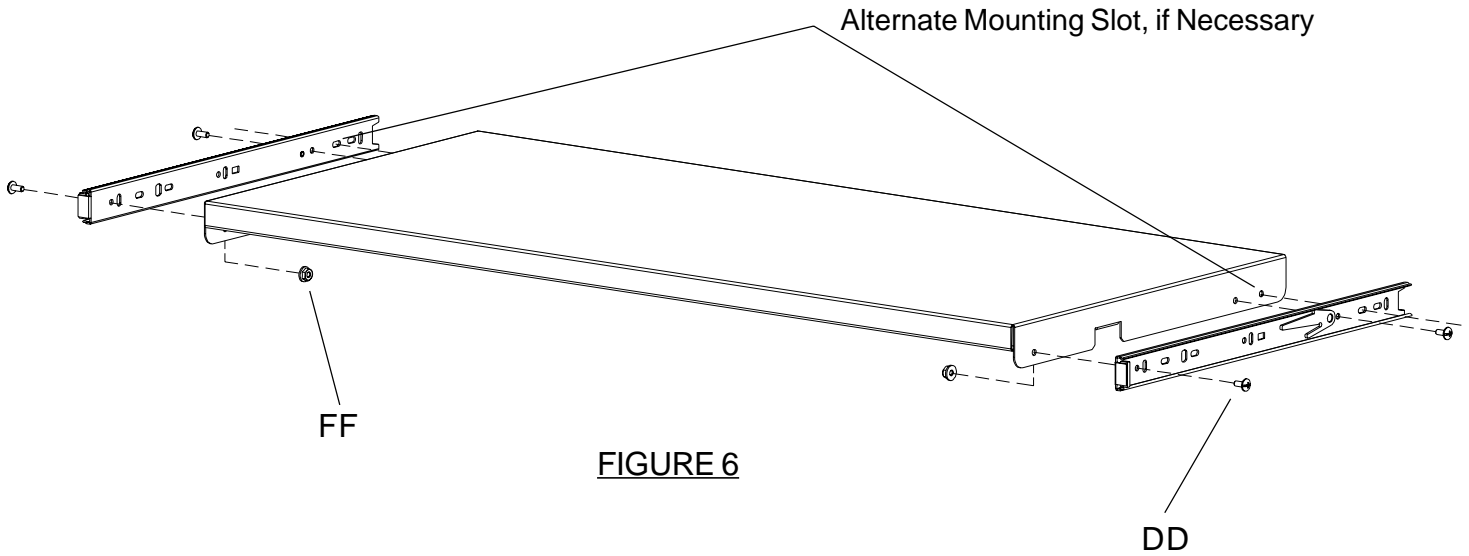

FIGURE 6

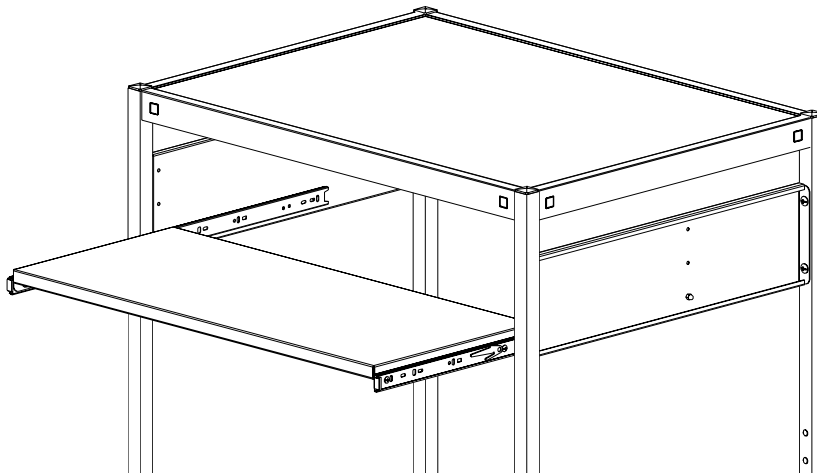

FIGURE 7

STEP 7

Attach the remaining slide pieces to the pull out shelf with screws (DD) and nuts (FF) as shown in **FIGURE 6**. Then slide shelf into cart as shown in **FIGURE 7**.



FF

Bretford
 11000 Seymour Avenue
 Franklin Park, IL 60131
 TEL: 847.678.2545
 800.521.9614
 FAX: 847.678.0852
 800.343.1779

Bretford Ltd.
 Technology House
 7 Lake End Court, Taplow
 Bucks SL6 0JQ England
 TEL: 01628 603558
 FAX: 01628 604923

www.bretford.com

Part# 031-1722
 Rev. 07.13.06 CZ