



BRETFORD™

BBILSM52

MULTIMEDIA CART

Assembly Instructions

SAFETY WARNING

**Note: TWO PERSON
ASSEMBLY REQUIRED**

PARTS LIST

Qty	Part #	Description
2	010-4510	Shelf Support Brackets
1	010-4519	Cord Management Frame
1	010-4518	6" Cord Management Panel
1	010-4517	9" Cord Management Panel
2	010-2436	Safety Belt Brackets
1	010-2658	Mouse Pad Mounting Bracket
1	022-2050	Left Front Leg Assembly
1	022-2051	Right Front Leg Assembly
1	022-2052	Left Rear Leg Assembly
1	022-2053	Right Rear Leg Assembly
1	010-3374	Back Panel
1	010-4516	Slide Out Shelf
1	030-1191	14" Full Extension Slide
1	022-2047	Top Shelf Assembly
1	022-2048	Middle Shelf Assembly
1	022-2049	Bottom Shelf Assembly
1	022-1825	Mouse Pad Assembly
1	015-0104	5" Plate Caster w/o Brake
1	015-0087	5" Plate Caster w/ Brake
1	SBRT	Ratchet Safety Belt
1	UCSE10	10 Outlet E Unit

HARDWARE LIST

Ref.	Qty	Part #	Description
AA	30	030-0300	5/8" Square Head Bolts
BB	30	030-0002	5/16-18 Serrated Nuts
CC	12	030-0307	5/16-18 x 5/8" Hex Screws
DD	4	030-0304	1/4-20 x 5/8" Truss Head Screws
EE	4	030-0256	1/4-20 Flange Nuts
GG	2	030-0428	2 11/32" Washers
HH	1	030-0427	Nylon Washer
II	1	030-0306	1" x 21/64" Washer
JJ	1	030-0421	5/16-18 Lock Nut
KK	16	030-0325	1/4-20 x 1/2" Truss Head Screws
LL	2	010-2841	Mouse Pad Brackets
MM	4	030-1228	#8-32 x 1/4" Truss Head Screws
NN	4	030-1203	#8-32 Acorn Nuts
OO	4	030-0302	#8-32 x 3/8" Combo Truss Screws
PP	4	02236	8-32 Hex Flange Nuts
QQ	1	010-3487	Spacer
	1	010-1106	Hex Wrench

TOOLS REQUIRED

- Phillips Screwdriver
- 1/2" Box Wrench
- Hex Wrench (Supplied)

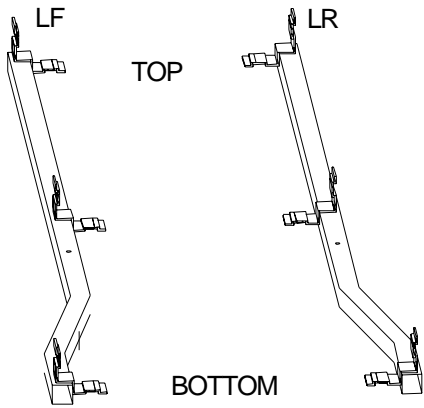

FIGURE 1

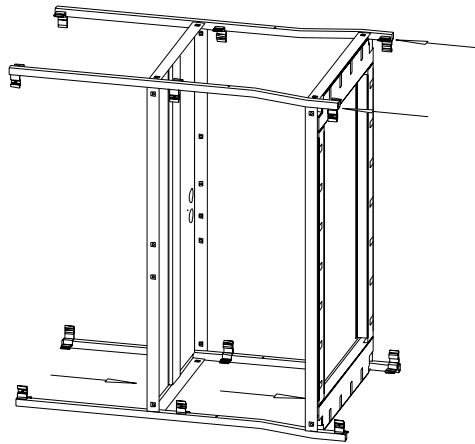

FIGURE 2
FRONT VIEW

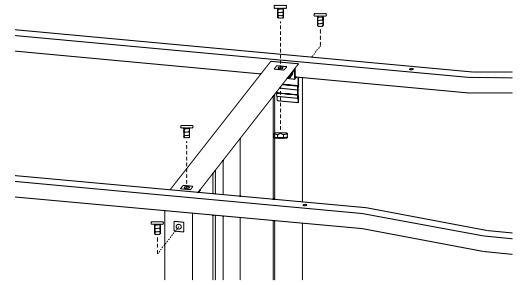

FIGURE 3

STEP 1

Lay the left legs side by side on a carpeted surface as shown in **Figure 1**. Slide the bottom and middle shelves onto the legs so the leg brackets are inside the shelves. (The 6 square embossed holes on the middle shelf face the back). Then slide the right legs on to the shelves. **Figure 2**. In each corner, **LOOSELY** attach shelves with bolts (AA) and nuts (BB) as shown in **Figure 3**.

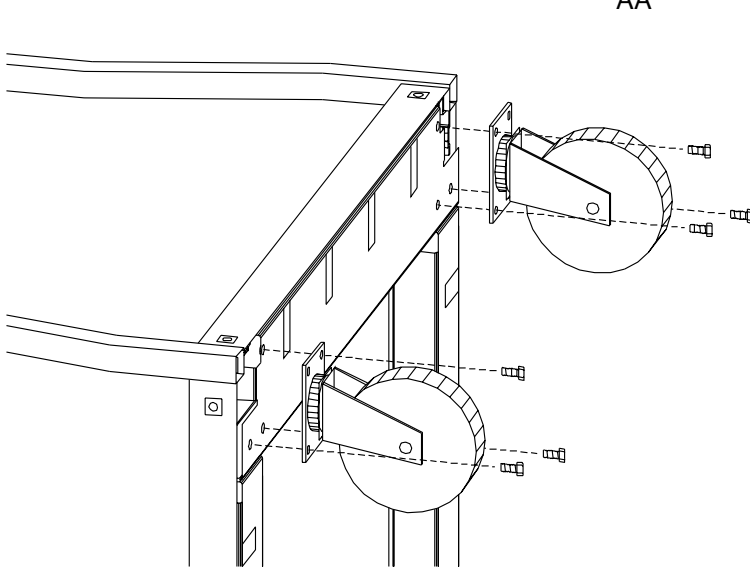
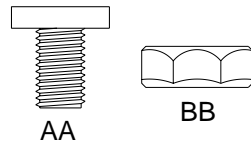

FIGURE 4

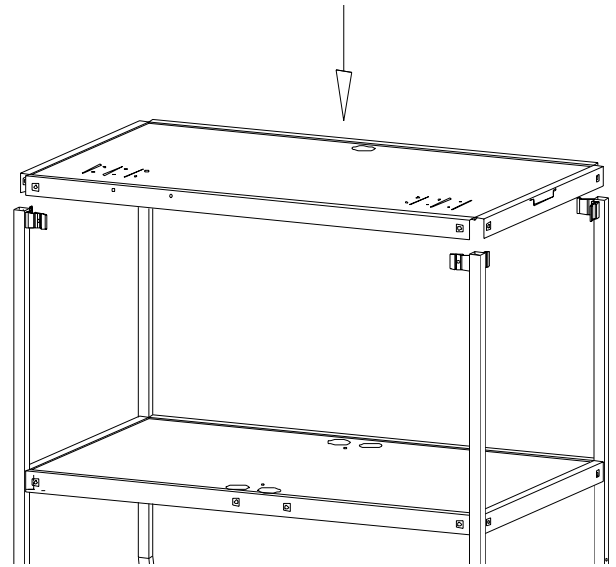
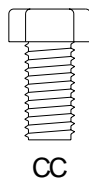

FIGURE 5
FRONT VIEW

STEP 2

Before attaching casters, **SECURELY TIGHTEN ALL BOTTOM SHELF HARDWARE**. Attach casters with screws (CC) as shown in **Figure 4**. It would be easier to attach the 2 upper casters first and then turn unit over and attach the 2 remaining casters. Stand unit upright and slide on top shelf with slots facing front (**Figure 5**). Attach with bolts (AA) and nuts (BB). Casters with locking brakes should be installed at the short side of the unit (left or right). **TIGHTEN ALL SHELF HARDWARE.**



CC

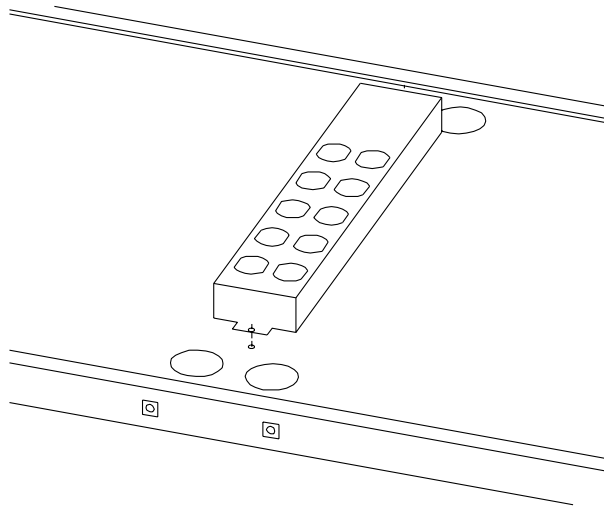

STEP 3

Attach E-unit to middle shelf with hardware enclosed in pack.

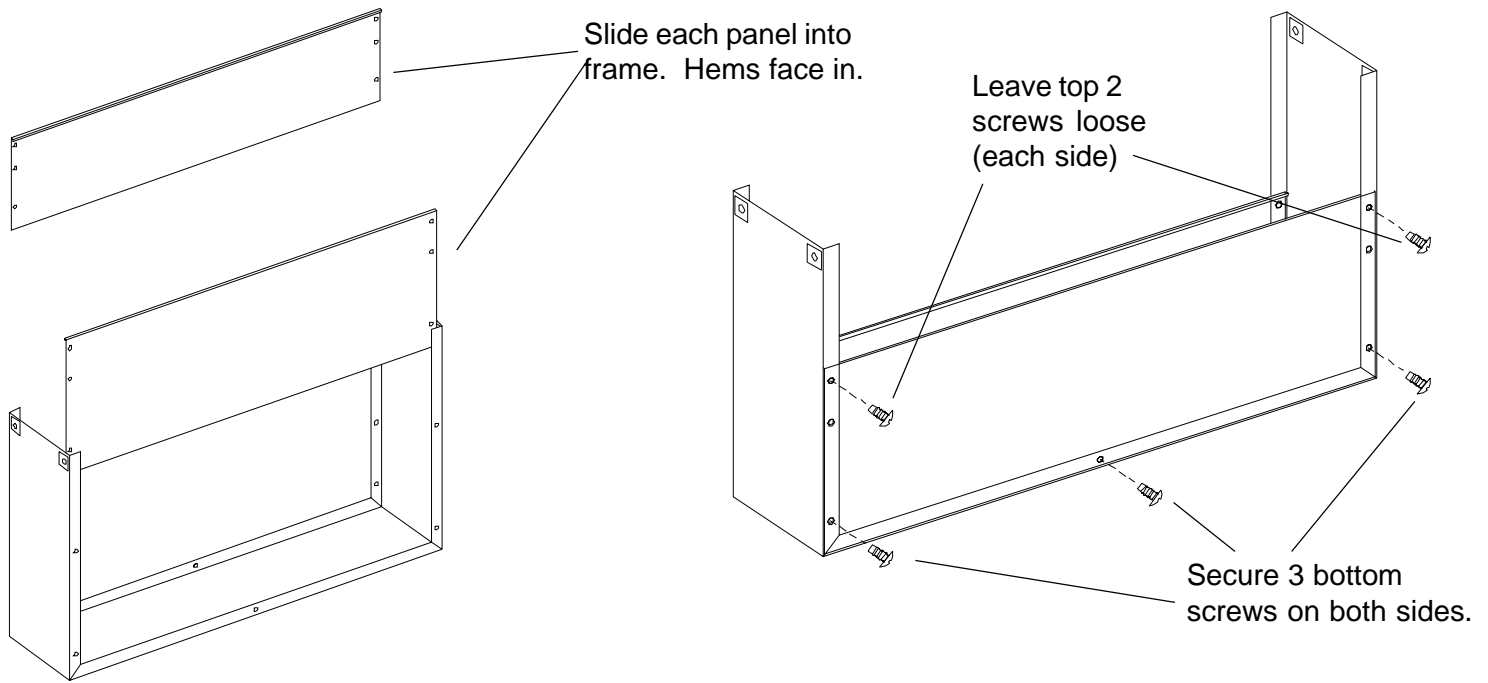
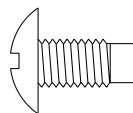

FIGURE 6

FIGURE 7

STEP 4

Slide each cord management panel down into frame with **hems facing in** as shown in **Figure 6**. Attach each panel with screws (KK) as shown in **Figure 7**.



KK

Secure on both sides of middle shelf.

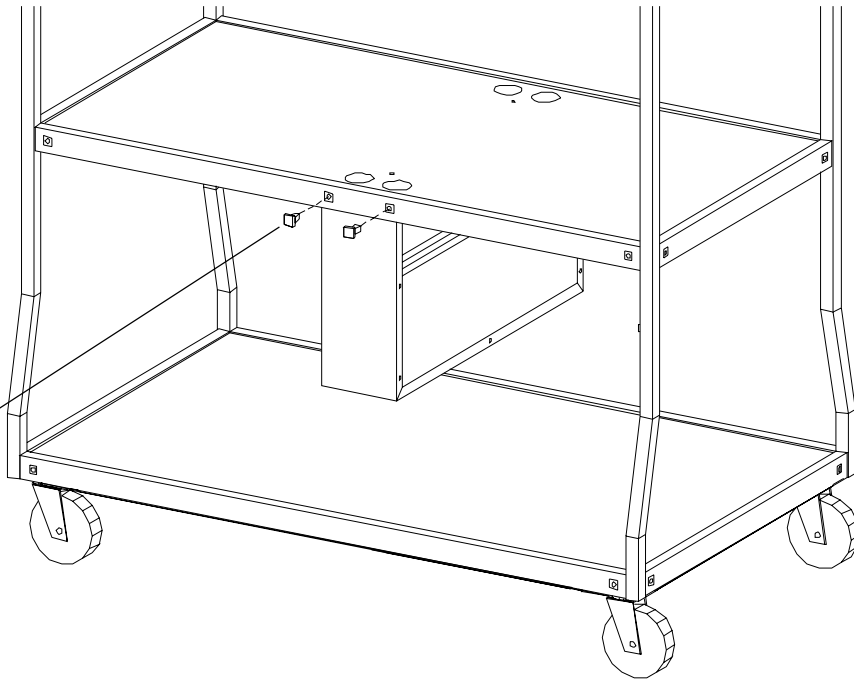

STEP 5

Attach cord bin under the middle shelf with bolts (AA) and nuts (BB) as shown. **NOTE:** Make sure you attach both sides.

SHELF SUPPORT BRACKET

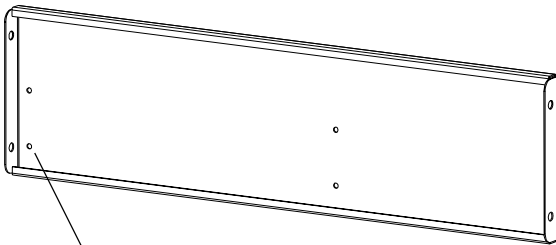

THESE HOLES MUST FACE THE LEGS

ATTACH TO LEGS WITH SCREWS (DD). **MUST ATTACH THESE FIRST**

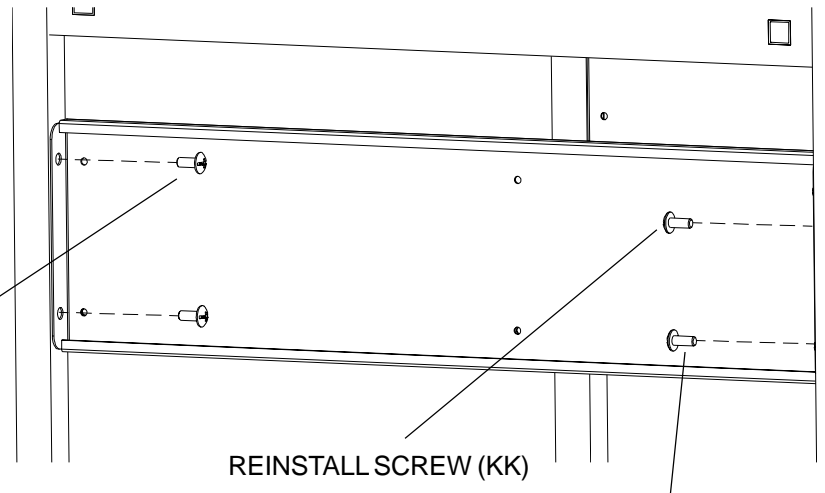

REINSTALL SCREW (KK)

INSTALL ADDITIONAL (KK)

STEP 6

Attach the support brackets between the legs and cord bin frame as shown. **NOTE:** Align and attach bracket to the **LEG SIDE FIRST** with screws (DD). Remove upper cord bin frame screw and install additional screw (KK) to secure bracket to frame.

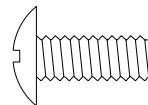

DD

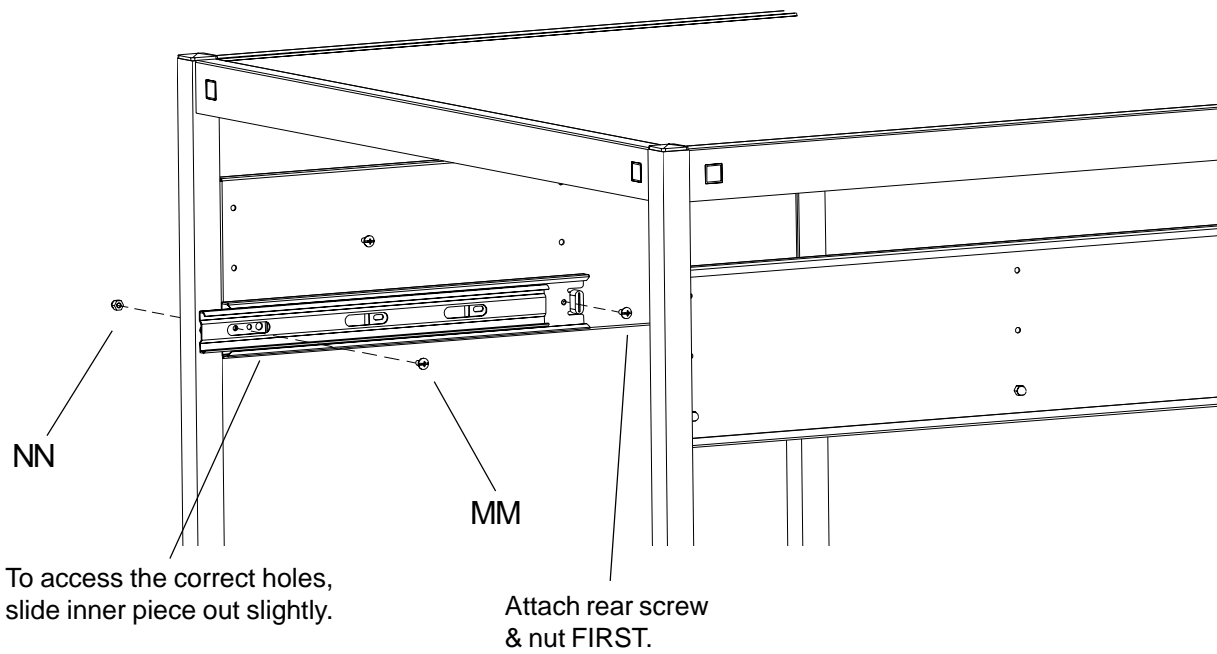

STEP 7

Separate each slide and attach the outer section to the inside of each shelf support bracket with screws (MM) and nuts (NN) as shown. **NOTE: Attach rear screw and nut first.**

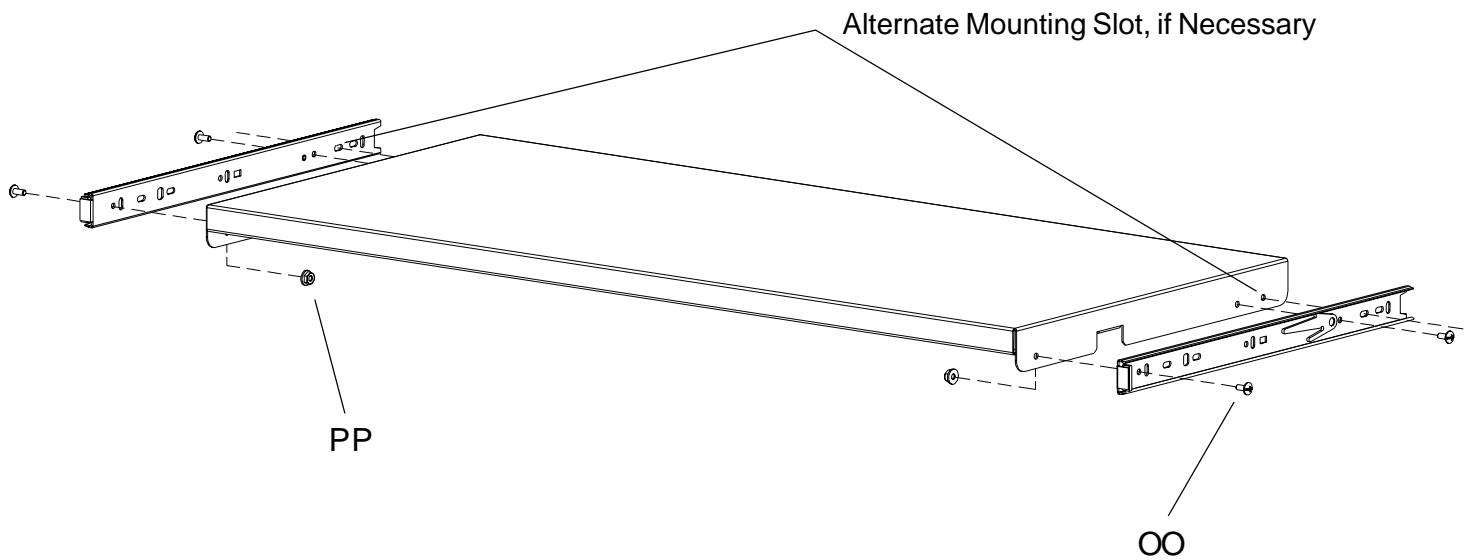

STEP 8

Attach the remaining slide pieces to the pull out shelf with screws (OO) and nuts (PP) as shown.

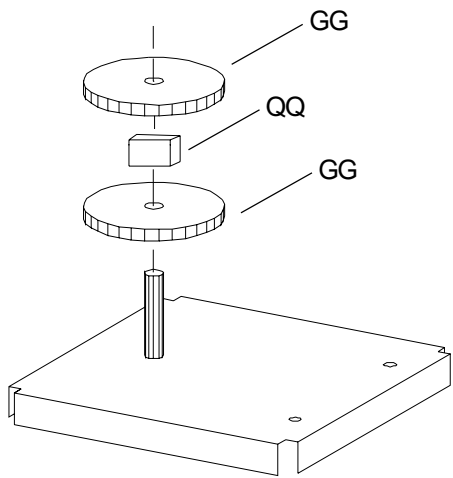

FIGURE 8

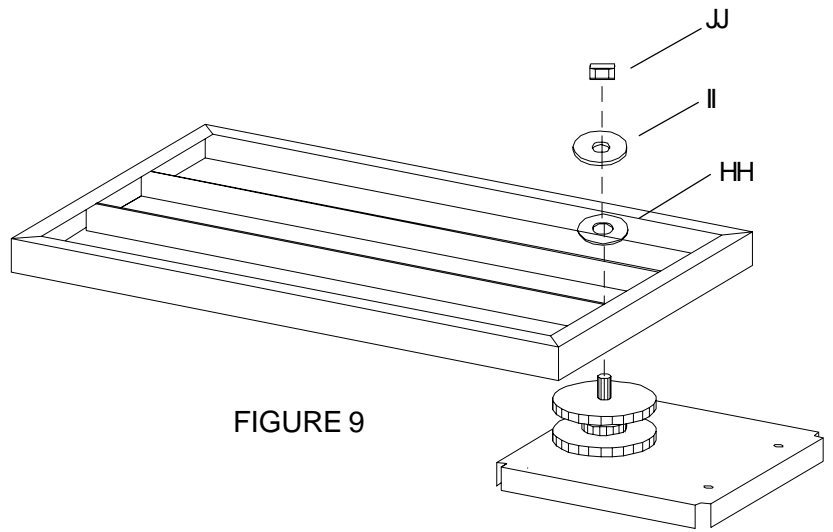

FIGURE 9

STEP 9

Lay the mouse pad mounting bracket down with the welded bolt facing up and slide on the following 1 big washers (GG), spacer (QQ) and another washer (GG) as shown in **FIGURE 8**. Next slide on the mouse pad assembly, nylon washer (HH), steel washer (II) and lock nut (JJ) onto the welded bolt as shown in **FIGURE 9**. **TIGHTEN NUT TO SECURE ENTIRE CONNECTION.**

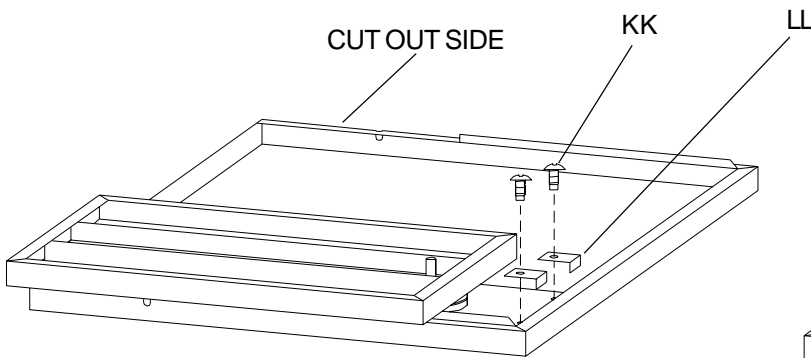
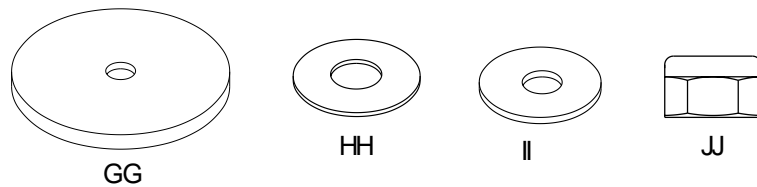

FIGURE 10

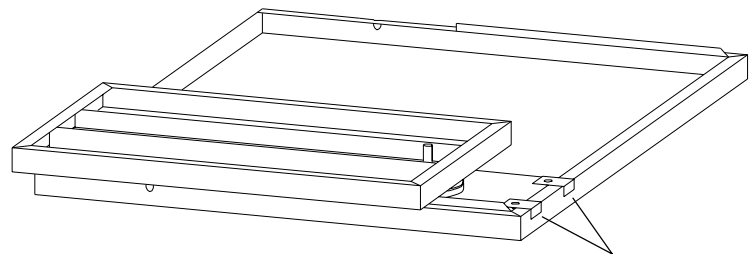
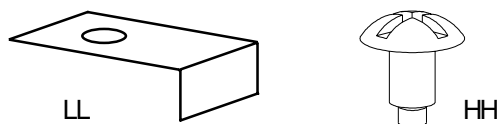

FIGURE 11

BRACKET POSITION
ONCE SECURED

STEP 10

Slide the mouse pad into the corner of the slide out shelf (the one without the cut out) on the side away from the cut outs, so that it is tucked under the shelf flange (**FIGURE 10**). The mouse pad can be attached to either the right or left side of the shelf. Secure in place using screws (KK) and brackets as shown in **Figure 10**. **Figure 11** shows how the mounting bracket is clamped under the shelf flange and the brackets will sit on top of the shelf flange once secured in place.



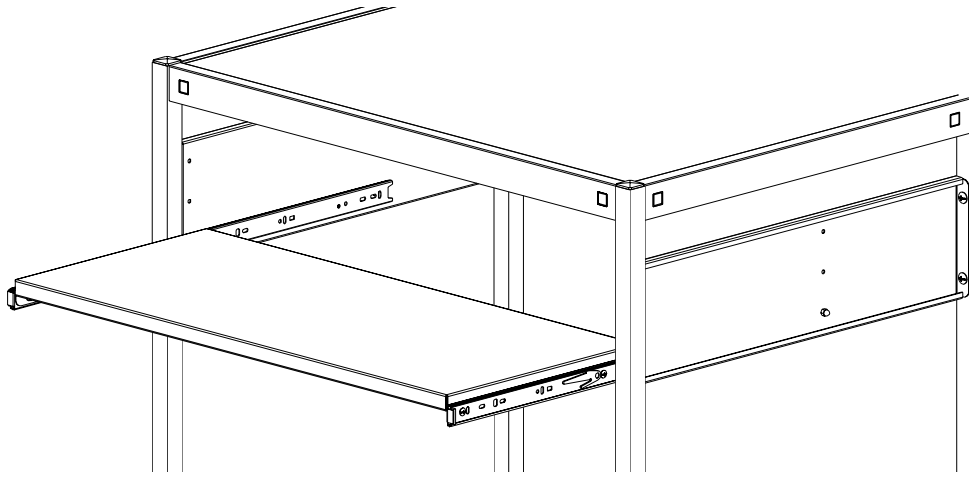

STEP 11

Slide the shelf onto the slides as shown.

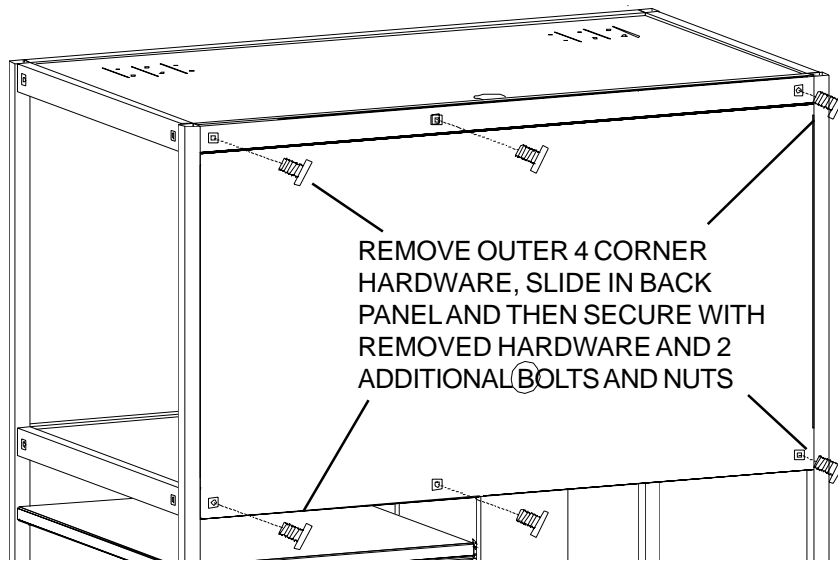

STEP 12

To attach back panel, take off bolts (AA) and nuts (BB) on top and middle shelves (4 corners). Slide back panel top edge into unit so that it sits in front of the top shelf brackets. Use bolts and nuts (AA, BB) taken off and additional bolts and nuts (AA, BB) to secure the back panel onto the unit.

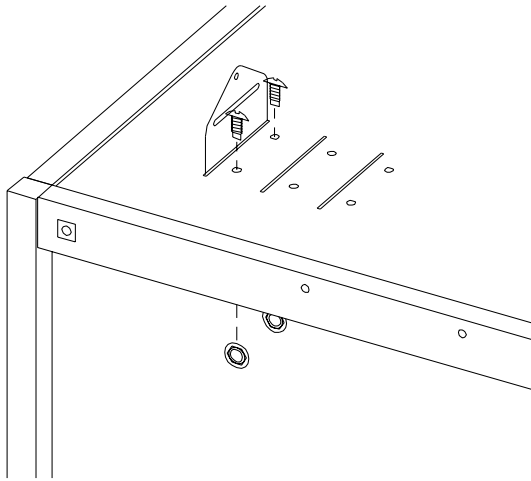

STEP 13

Attach brackets for safety belt with screws (KK) and nuts (EE) as shown. Spacing for brackets is determined by TV size. **NOTE:** Secure safety belt using the instructions enclosed in its package.



EE

Bretford
11000 Seymour Avenue
Franklin Park, IL 60131
TEL: 847.678.2545
800.521.9614
FAX: 847.678.0852
800.343.1779

Bretford Ltd.
2 Etongate
110 Windsor Road
Slough, Berkshire SL1 2JA England
TEL: 01753 216531
FAX: 01753 539478

www.bretford.com

Part # 031-3690
Rev. 07.13.06 CZ