

CR8526 Overhead Projector Cart Assembly Instructions

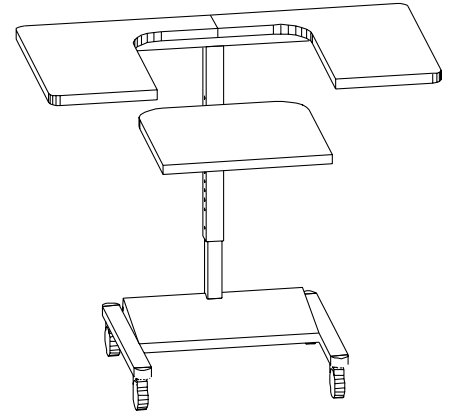

PARTS LIST

Qty	Part#	Description
1	SA1696	3 Piece Wood Top (Grey)
	SA1697	3 Piece Wood Top (Oak)
1	022-1611	Upper Section Assembly
1	022-1612	Shelf Carriage Assembly (Comes attached to part #022-1611)
1	022-1613	Bottom Base Assembly

HARDWARE LIST

Qty	Part#	Description
10	030-0402	#10-32 x 5/8" Combo Screw
2	015-0085	3" Caster w/o Brake
2	015-0089	3" Caster w/ Brake

TOOLS REQUIRED

Phillips Screwdriver
Adjustable Wrench

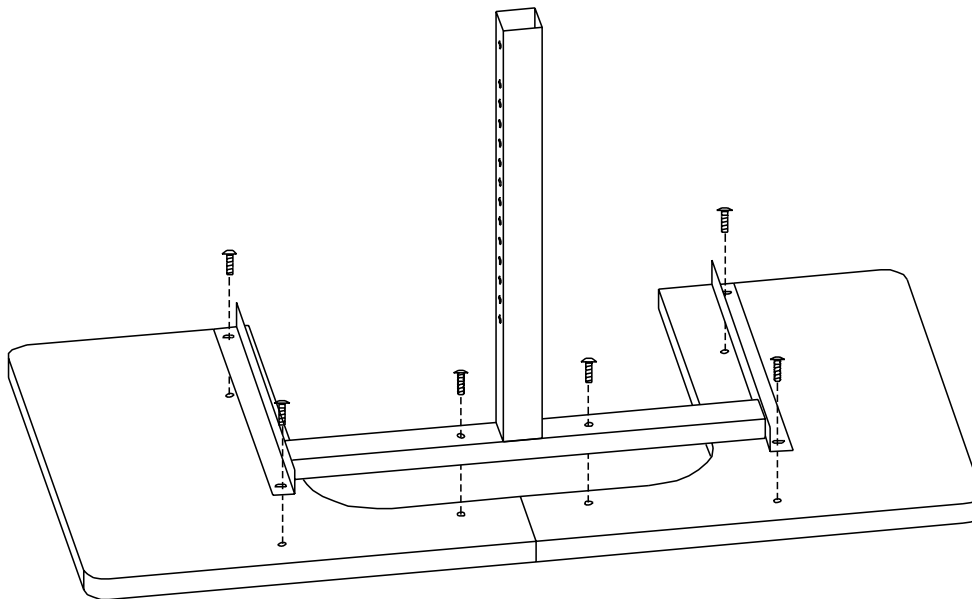

STEP 1

Lay the 2 work surface pieces on a clean flat surface with holes facing upward. Attach upper/bottom assembly to surface with screws as shown.

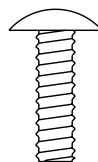

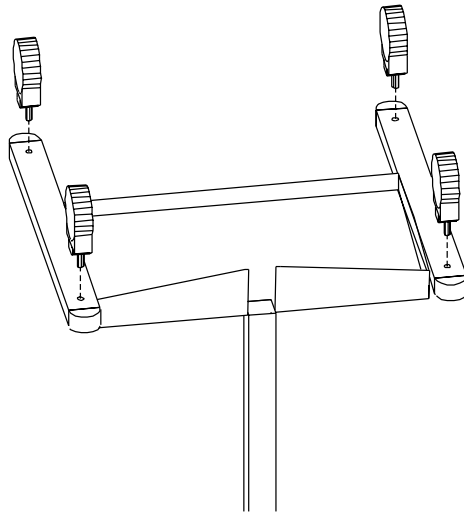

STEP 2

Twist on casters to the bottom assembly. Make sure casters are securely in place and stand unit upright. **NOTE:** When tightening the casters, the wheel may pull away from the nut. This is OK; just tap the wheel back into the nut. Also when loosening the casters, you may have to pull the wheel away from the nut in order to get your wrench around the nut.

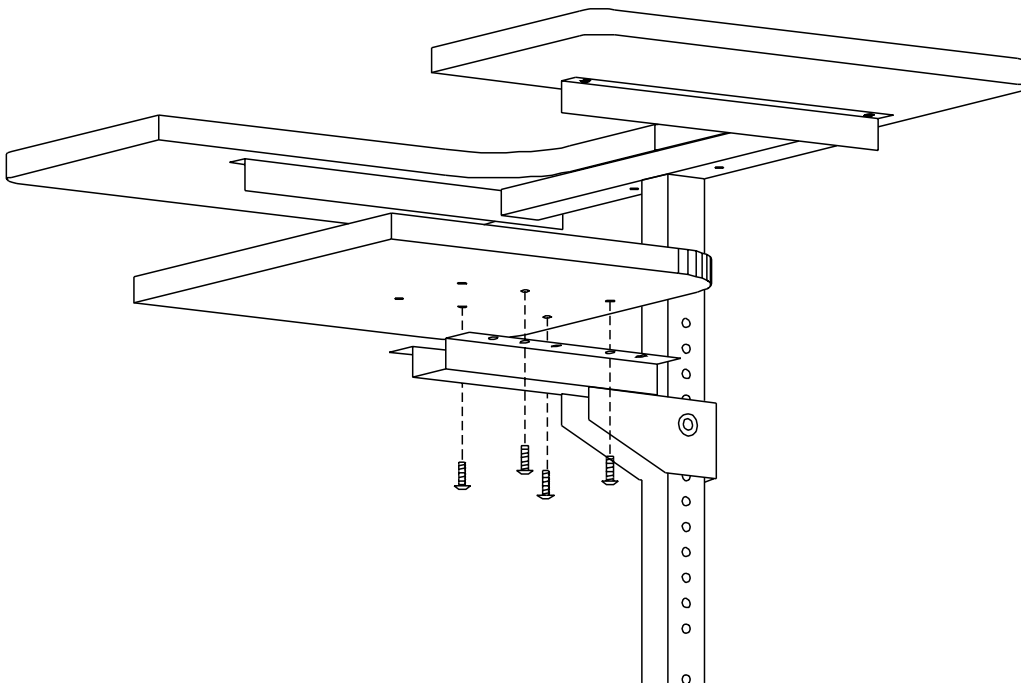

STEP 3

Attach shelf to carriage assembly with screws as shown. The decision of which holes to use depends on the size of your projector. To adjust the height of the shelf assembly, loosen knob and pull out plunger, move assembly to desired height and release plunger into nearest hole and tighten knob.

CAUTION: When adjusting height of shelf assembly, **DO NOT EXCEED THE INTENDED POINT INDICATED ON YELLOW CAUTION LABEL.**

Bretford
 11000 Seymour Avenue
 Franklin Park, IL 60131
 TEL: 847.678.2545
 800.521.9614
 FAX: 847.678.0852
 800.343.1779

Bretford Ltd.
 Technology House
 7 Lake End Court, Taplow
 Bucks SL6 0JQ England
 TEL: 01628 603558
 FAX: 01628 604923

www.bretford.com

Part #031-1640
 Rev. 4.96 CH