

⚠ WARNING

- For stability, TV must be placed in center of top shelf.
- Do not tip cart with TV in place.
- The use of safety belt model ACC666 (ordered separately), to secure TV to shelf, is recommended.

UL US This product is intended for use with UL Listed products and must be installed by a qualified professional installer.
Product is UL rated up to 27" TV, 125 lbs.

IMPORTANT!

- Do not use cart for TV's larger than 27".
- Read entire instruction sheet before you start assembly and installation.

Parts List

Before you start make sure all parts listed are included with your product.

PART #	QTY.	DESCRIPTION
A 009-1127	1	Cart (JCT 100)
009-1129	1	Cart (JCT 200)
B 600-0034	2	Rigid Caster
C 600-0035	2	Swivel Caster with brake
D 520-9209	16	5/16" dia. 3/4" Carriage Bolt
E 540-9406	16	Flat Washer
F 530-9306	16	Nylock Nut

Some parts may appear slightly different than illustrated.

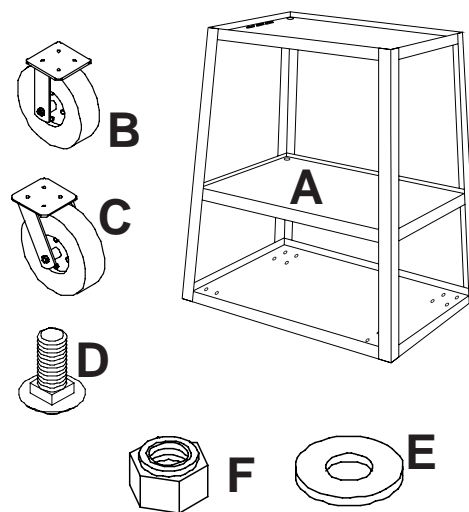

- 1** Inflate tires to a minimum of 25 lbs. Turn Cart (A) upside down for wheel attachment. Attach two rigid wheels (C) to one end of the Cart and two swivel wheels (B) to the other end. Attach each wheel using four 5/16-18 x 3/4" carriage bolts (D), washers (E) and nylock nuts (F). Tighten securely.

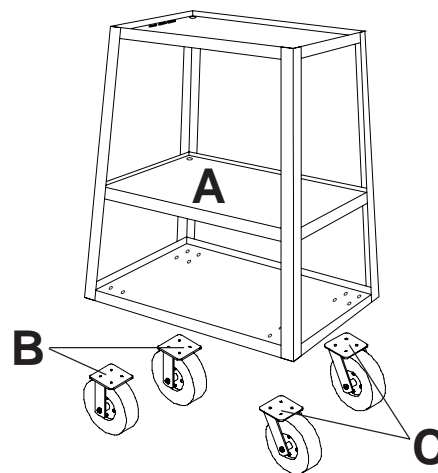
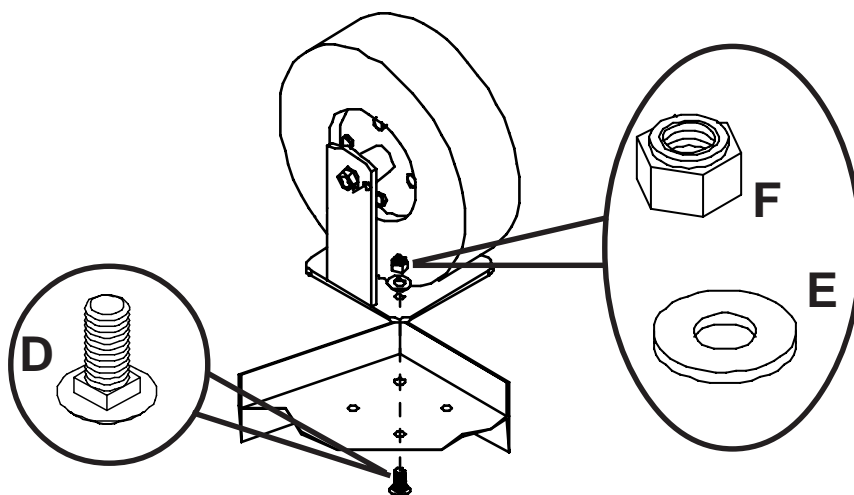

Electrical Outlet Box

Model: ACC551 or ACC552 (MUST BE ORDERED SEPARATELY)

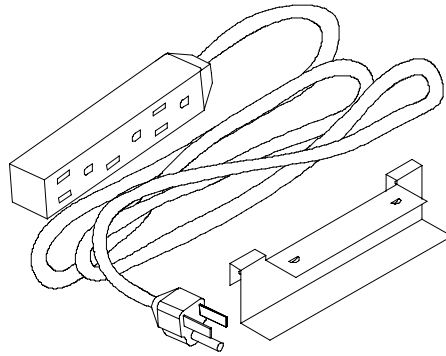

MODEL # ACC551

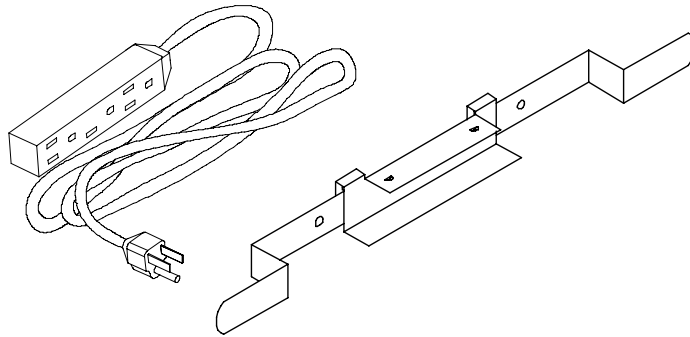

MODEL # ACC552